

subLOGIC Scenery Disk

Database Design by Michael Woodley

© 1985 SubLOGIC Corporation
First Edition
First Printing
All Rights Reserved
SubLOGIC Corporation
713 Edgebrook Drive
Champaign, IL 61820

Database Design by Michael Woodley



Introduction

SubLOGIC Scenery Disks are an enhancement designed to expand the potential flying environment of Flight Simulator II and other SubLOGIC flight simulation programs. You must have Flight Simulator II, Microsoft Flight Simulator, or Jet in order to use a Scenery Disk.

Twelve separate Scenery Disks covering the entire continental United States were developed using NOAA (National Oceanic and Atmospheric Administration) Sectional Aeronautical Charts and Airport/Facility Directories. These charts divide the United States into 37 different sectionals. Each sectional includes all of the airfields and radio-navigation aids in the area covered by the chart. Sectional charts also show topographical information and obstacles that are important to aviators. Scenery Disk databases were digitized from these NOAA sectionals.

Scenery Disks include enough radio-navigation aids and visual scenery to allow the user to navigate anywhere in the sectional areas covered. A typical Scenery Disk (SD) covers three aeronautical sectionals, and includes approximately 100 airports and 100 radio-nav aids. Some SD's may have more airports and radio-nav aids, since some areas of the country are more densely populated than others. Any of these SD's are ideal for simulating cross-country flights.

SubLOGIC Scenery Disks are grouped by aeronautical sectional. Each SD covers a geographical region of the United States, generally comprised of three sectionals:

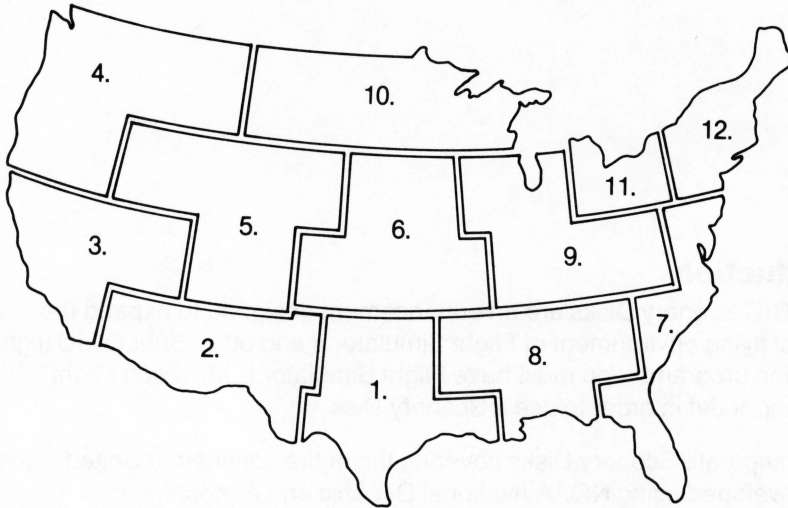

WEST

- 1. Dallas – Ft. Worth
Houston
San Antonio
Brownsville
- 2. Phoenix
Albuquerque
El Paso
- 3. San Francisco
Los Angeles
Las Vegas
- 4. Klamath Falls
Seattle
Great Falls
- 5. Salt Lake City
Cheyenne
Denver
- 6. Omaha
Wichita
Kansas City

EAST

- 7. Washington
Charlotte
Jacksonville
Miami
- 8. Memphis
Atlanta
New Orleans
- 9. Chicago
St. Louis
Cincinnati
- 10. Billings
Twin Cities
Green Bay
- 11. Lake Huron
Detroit
- 12. Halifax
Montreal
New York

In addition to twelve regional Scenery Disks, a number of STAR Scenery Disks are also available. A STAR Scenery Disk covers a small area with a relatively dense amount of scenery. These disks are mainly intended for visual flight (sight-seeing). They include buildings and landmarks, as well as detailed renditions of the major airports in the area.

Reading a Sectional Directory

Below is a sample listing from a sectional directory with a description of the information provided. All available airports and radio-nav aids for a given sectional are listed alphabetically. Radio transmitters that border a sectional are also available on neighboring sectionals, so you can cross sectional boundaries when instrument flying.

1 — 2 - ALBUQUERQUE AND EL PASO — 2

3 — Alpine

4 — 12628N 10661E — 5

6 — alt. 4513

7 — RWY 1-19
RWY 5-23

8 — 5999 X 72
4821 X 39

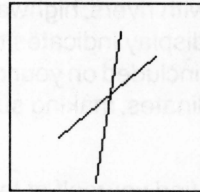

9 — Anton Chico (VOR) — 10

4 — 14710N 10537E — 5

11 — freq. 110

9 — Artesia (NDB) — 10

4 — 13703N 10575E — 5

11 — freq. 414

- | |
|------------------------------|
| 1 Page number |
| 2 Sectional name |
| 3 Airport name |
| 4 North coordinate |
| 5 East coordinate |
| 6 Altitude in feet |
| 7 Runway Designator, number |
| 8 Runway dimensions in feet |
| 9 Radio Aid name |
| 10 Radio Aid type designator |
| 11 Radio Aid frequency |

Notice that the vertical sides of the airport map align with magnetic north. Magnetic north is the direction you are pointing when your magnetic compass reads 0. Each sectional map's VOR needles point toward magnetic north. The sides of the map align with true north. This is consistent with NOAA sectionals.

Using a Scenery Disk with Flight Simulator II

Load Flight Simulator II in the usual way. When the program has finished loading, enter the simulator's program editor as described in your operating manual and set the NORTH and EAST coordinates of the airport you've chosen from the directory for the region you'd like to explore (set ALTITUDE to 0). Exit the editor, remove the FSII disk and insert the appropriate Scenery Disk. Next, press CTRL E and wait for a menu to appear. This menu page lists the names of the sectionals included on the Scenery Disk. Press any key to exit, and you should find yourself at the airport you've selected. If no scenery is visible, go into radar mode and zoom out to determine your approximate location. You may be able to zoom all the way out and view the entire continental United States database, complete with rivers, highways, coastlines, and the Great Lakes. This default database display indicates that you are not within the boundaries of the sectionals included on your disk. Re-enter the program editor and double-check your coordinates, making sure that both NORTH and EAST coordinates are correct.

When you find yourself at the airport you've selected, it may be a good idea to save your position to a User Mode (see User Mode Library in the FSII Pilot's Operating Handbook). This way, if you crash, you will be returned to the selected airport. Otherwise you will be returned to a preset location (above Lake Michigan) in the default USA database.

Crossing a Sectional Boundary

When you fly over a sectional boundary, one of two things will occur. If the neighboring sectional is also included on your Scenery Disk, that sectional will load and you will have to switch to the appropriate new map and directory provided. If the neighboring sectional is not available on your disk, a common default USA database will load. This default database allows you to zoom out (in radar mode) to view the major geographical features of the United States.

If you have another Scenery Disk containing the appropriate sectional, you can switch disks and press CTRL E to log-in the new disk. After a brief load, the names of the new sectionals available on this disk will be displayed. Press any key to exit and return to Flight Simulator II.

IMPORTANT - If you want to change Scenery Disks or go back to the scenery on the FS2 disk, you must log-in the new disk by pressing CTRL E. If you do not log-in the new disk, you will not get the new scenery and you will risk causing a disk load error.

Using a Scenery Disk with Microsoft Flight Simulator (IBM PC Versions)

Load Flight Simulator in the usual way. When you want to switch to a Scenery Disk, remove the Flight Simulator disk and insert the appropriate Scenery Disk. Press CTRL E. This will log-in the disk. A message will appear on the screen identifying the names of the sectional areas contained on the disk.

The first Scenery Disk log-in automatically checks to see if you have the most recent version of Flight Simulator. If you don't, the program updates Flight Simulator in memory. When this happens, your flight coordinates are set back to the Chicago area. This will only happen on the first Scenery Disk log-in of the session. After the first log-in, your flight coordinates and conditions will carry over as you change Scenery Disks while flying.

After logging in the first Scenery Disk, you can fly or slew through all of the scenery on the disk. You can freely exchange Scenery Disks as you fly to new areas. Press CTRL E to log-in the new area when you switch disks. If you fail to log-in a new Scenery Disk after inserting it, it will be automatically logged in when the disk is accessed. The log-in message will appear after every manual or automatic log-in.

Using the Microsoft Flight Simulator Disk as a Scenery Disk

The Flight Simulator disk contains all of the usual scenery for the Chicago, Seattle, Los Angeles, and New York areas. You can insert this disk and log it in as you would any other Scenery Disk to fly in these areas. This applies to Jet as well as Flight Simulator.

Special Note for IBM PC Flight Simulator Version 2.0

Very few copies of Version 2.0 exist. You most likely have Version 2.1, 2.10, 2.10a, 2.12, or a later version of Microsoft Flight Simulator. Look on the disk label near the serial number area, or look on the first menu page when loading Flight Simulator. If you have Version 2.0, insert the Scenery Disk and press ESC instead of CTRL E for the first log-in of the session. After this first log-in, press CTRL E as usual to log-in new Scenery Disks. Also, never re-insert the Version 2.0 disk to use the Chicago, Seattle, Los Angeles, or New York scenery; you must re-boot Version 2.0 to return to these areas. Version 2.0 also cannot be used as a Scenery Disk for Jet.

Tandy 1000/1200/2000 Flight Simulator

Scenery Disks are compatible with the Tandy 1000/1200/2000 version of Flight Simulator. With this version, always make sure to log-in a new Scenery Disk by pressing CTRL E once the disk has been inserted. No auto-load is available on this version, and failure to log-in a new disk can cause unpredictable results when the disk is accessed after an unlogged disk change.

Special Note for Compaq 286 Users

The 1.2Mbyte floppy drives in the Compaq Deskpro 286 computer cause disk-read errors when using Scenery Disks with SubLOGIC Jet or Microsoft Flight Simulator. Here is the reason why, and how to get around it:

PROBLEM - Whenever you remove a disk from the floppy drive by turning the release lever, the diskette springs out of the drive. This spring action triggers a switch in the drive that informs the disk read/write software that you have just changed the disk. The software assumes that you are about to insert a new disk, and switches to 1.2Mbyte read mode from whatever mode it happens to be in. Jet, Flight Simulator, Scenery Disks (and many other manufacturers programs) are on 360K disks, and a read error results when the Compaq 286 tries to read them as 1.2Mbyte disks.

You can verify this for yourself using the Microsoft Flight Simulator. Boot the disk, then enter and exit the editor several times (ESC key) just to see that everything is functioning properly. Then pop the disk out of the drive, re-insert it, and try to get back into the program editor. You will get a disk read error.

SOLUTION - You can avoid this problem by tricking the disk drive into thinking that you haven't changed disks. Do this by holding the disk in place with your finger while releasing the disk-release lever. **DON'T LET THE DISK POP OUT OF THE DRIVE.** Then manually remove the disk and insert a Scenery Disk (or Flight Simulator as scenery for Jet). The computer will never know that you changed the disk, and everything should work fine. Remember - if you let the disk pop itself out of the drive, the switch will be activated and the drive will go into 1.2Mbyte mode, thus creating errors.

Jet Users

Scenery Disks are compatible with SubLOGIC Jet. Follow the instructions in your Jet manual for loading a Scenery Disk. Jet has no automatic log-in feature, so always make sure you return to the Jet startup menu page before inserting a new Scenery disk. Changing Scenery Disks in the middle of a Jet flight can cause unpredictable results when the disk is accessed after a disk change.

Conclusion

As of this writing there are no fuel or repair facilities available on regular Scenery Disks (although they do occur on STAR Scenery Disks). To refuel, just land at an airport and enter the program editor. Your tanks will be filled and repairs will be made when you exit the editor.

We intend to periodically update and improve our Scenery Disks to include more airports, radio aids, and scenery details as recommended by users. If you know of an airport (or any other detail) that should be included on future versions of these Scenery Disks, please drop us a line and include the required information ON A SEPARATE SHEET OF PAPER (so we can store it in our files). Here's what we need to know:

Airports: NAME, CITY, & STATE
 LATITUDE, LONGITUDE, & ALTITUDE
 HEADING, LENGTH, & WIDTH of each runway

Buildings, objects: NAME, CITY, & STATE
 LATITUDE, LONGITUDE, & DIMENSIONS

Pictures and postcards are also welcome, especially aerial views. If you're unable to determine the latitude and longitude for the object or airport in question, please provide a description of where the object can be located on a map. All customer correspondence is read and answered (when appropriate). And please; remember to include any scenery suggestions or information on a SEPARATE page of your letter.

Conclusion

As a result of this study, it is concluded that the use of a...
The results of this study indicate that the use of a...
It is recommended that the use of a...

The use of a...
It is recommended that the use of a...
The results of this study indicate that the use of a...
It is recommended that the use of a...

NAME, CITY & STATE

LATITUDE, LONGITUDE & ALTITUDE

HEADING, LENGTH & WIDTH OF ROADWAY

NAME, CITY & STATE

LATITUDE, LONGITUDE & ELEVATION

Photos and other data are also available...
In order to determine the...
questionnaire...
map...
A...
SEPARATE PAGE...

Introduction to Scenery Disk # 7

Scenery Disk Design and Tool Development by Michael Woodley
Scenery Art by Loren Kirkwood

Maps & Directories by Michelle Maase, Ken Ruminski, & Toni Arcus

Scenery Disk # 7 pushes the entire scenery disk concept right to the limits; the disk storage space allocated to scenery is almost completely filled. We've used new techniques to improve scenery appearance, and included many new features not found on previous disks. SD# 7 includes highly-detailed areas for sight-seeing, as well as "generic" scenery areas with enough radio nav-aids and refueling facilities to keep you occupied for a long time. The following notes and recommendations will help you to explore these new scenery areas.

See the important government buildings and monuments in Washington DC; the Lincoln Memorial, Washington Monument, Capitol Building, White House, Pentagon, and more. (Buildings are only visible below 2,500 feet.) Set coordinates to:

North - 16135
East - 20192
Alt. - 16

Take off from Washington National Airport and head north.

Jacksonville is beautiful at twilight, with St. John's River meandering through the city and around several transmitter towers.

North - 12298
East - 19004
Alt. - 41

Take off at Craig Municipal Airport.

Visit NASA's facilities at Cape Canaveral; see a space shuttle on the launch pad, the Vehicle Assembly Building, shuttle landing strip, and a row of rocket gantry towers. Disregard FAA regulations and test your flight skills by weaving through the gantries as if they were pylons.

(continued)

North - 11519
East - 19408
Alt. - 10

Take off from Cape Canaveral Skid Pad and fly north.

Miami has an impressive skyline and two large international airports.

North - 10357
East - 19615
Alt. - 10

Take off from Miami International.

Follow Highway 1 south across causeways and islands all the way to Key West.

North - 10223
East - 19528
Alt. - 9

Take off from Homestead General Airport and head southeast to Highway 1.

Put those northern U.S. mid-winter blues in the ejection seat and take a trip to the sunny Bahamas!

North - 10737
East - 20209
Alt. - 7

Take off from Freeport International.

The improved radar view on this Scenery Disk will help you find your way home in slew mode if you accidentally fling yourself over the edge of the "world".

If you haven't learned how to use radio aids to navigate, now's the time. Start at Miami International:

North - 10357
East - 19615
Alt. - 10

Make sure you've got a full load of fuel, then taxi to runway 9R. Go to full throttle and take off!

Tune NAV1 to Bimini VOR (116.7). Set VOR heading to 96 degrees. After takeoff, turn to this heading. You should see buildings just to the right of the center of your screen. You may want to make a quick diversion to take a closer look, but be sure you then get back on course to the Bimini VOR. Take one last look out your back window at Miami. It's going to be a long flight.

When you reach Bimini tune NAV2 to Nassau VOR (112.7), change the setting on NAV1 to 114, and get on that radial. Follow this heading until you pick up Nassau VOR. When you pick up Nassau, tune NAV1 to 112.7 and fly to it. You will pass between Andros Island (on your right) and the Berry Islands when you are about 35 nautical miles (NM) from Nassau VOR.

You may want to land at Nassau International to refuel since we are touring the islands. From here, we will take the scenic route to Freeport International.

From Nassau, head towards Treasure Cay VOR and fly over Great Abaco Island. From Treasure Cay, fly on to Freeport and refuel. Then fly to Palm Beach International and tune COM1 to 123.75.

Another interesting flight path would be to take this route from Palm Beach to Miami and land on ILS runway 9R at Miami International.

Try flying non-stop from Key West to Tampa. There are no refueling facilities between these two areas and the distance is about 220 NM. This will test your stamina just like the Bahamian tour did.

Our favorite course is to fly from Atlantic City or Philadelphia to Miami and just follow the coastline for navigation. This flight can most easily be made in slew mode since it would take hours to actually fly.

Start from Norfolk and fly to Baltimore, then to Philadelphia by following the Chesapeake Bay to Baltimore.

Follow the Potomac River from its beginning to the Chesapeake Bay. Start at Dulles and fly up-river, then turn around. Be sure to stay below 2,500 feet MSL

when nearing Washington DC so you can view the details of the Mall, Pentagon, Washington Monument, Capitol Building, and other landmarks.

On the Charlotte Sectional, try flying ILS approaches or follow the railroads from city to city. A good route would be to fly from Savannah to Charleston, then on to Columbia, Charlotte, Winston-Salem, Raleigh-Durham, and Fayetteville.

The Jacksonville sectional features Cape Canaveral and Jacksonville as its main points of interest.

Above all else, explore! A lot of work went into this project. We hope that you enjoy the results as much as we do!

WASHINGTON

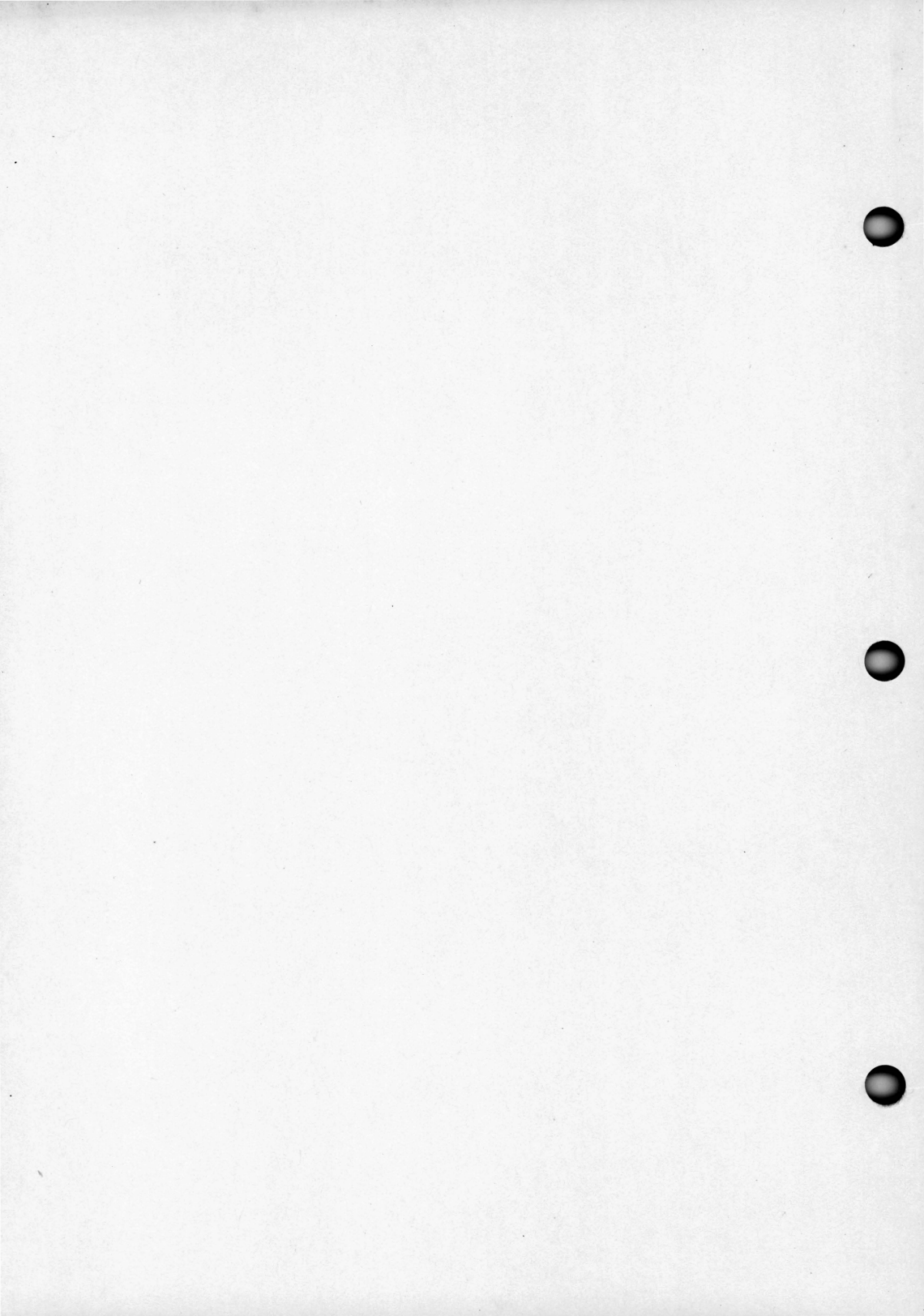

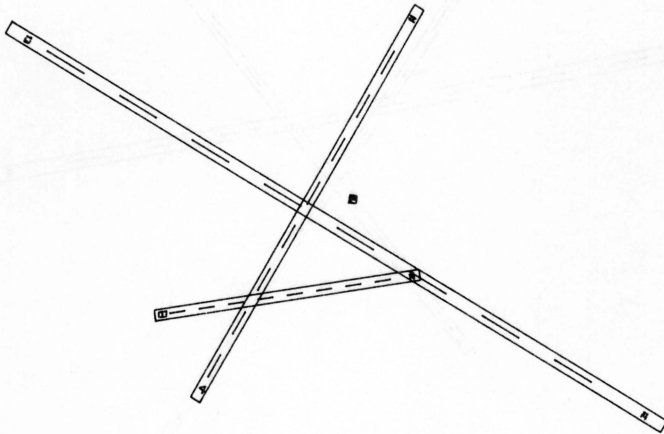

Atlantic City, NJ Atlantic City (F)

16507N 20982E
alt. 76

RWY 13-31 10000 X 180
RWY 04-22 6144 X 150

- WASHINGTON

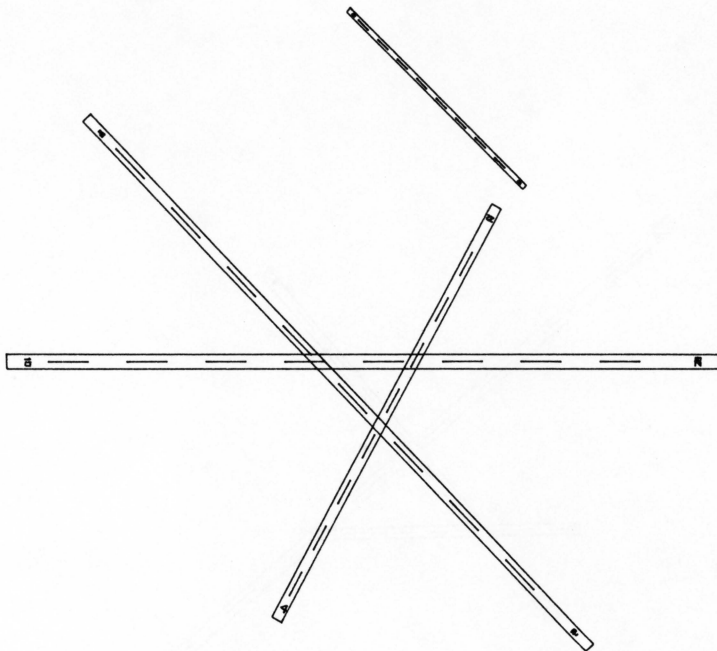

Baltimore, MD

Baltimore - Washington Int'l

16296N 20300E
alt. 146

RWY 15R-33L 9519 X 150
RWY 10-28 9452 X 200
RWY 04-22 6005 X 150
RWY 15L-33R 3199 X 75

ILS 33L
Frequency: 111.7
Heading: 332 degrees
Altitude: 1465 ft. @ LOM

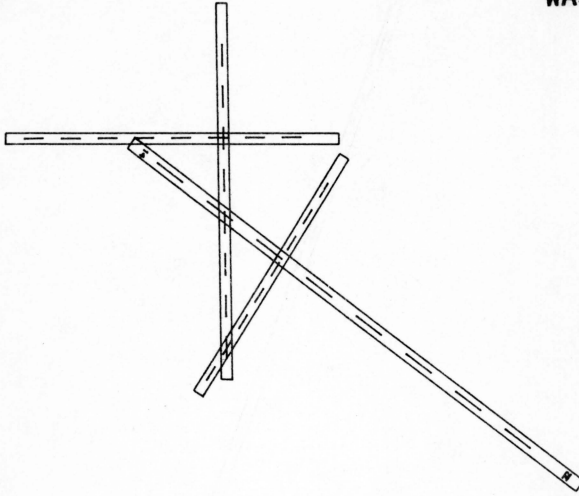

Baltimore, MD

Martin State

16367N 20376E
alt. 24

RWY 14-32 7000 X 180



Berlin, NJ

Camden-Burlington Co

16650N 20854E
alt. 138

RWY 05-23 2590 X 50

4 - WASHINGTON

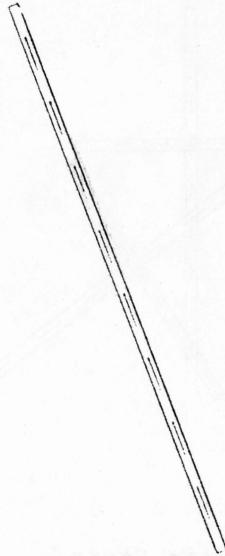

Cambridge, MD

Cambridge-Dorchester

16050N 20550E
alt. 20

RWY 16-34 4000 X 75



Dover - Cheswold, DE Delaware Airpark

16362N 20663E
alt. 56

RWY 09-27 3484 X 50

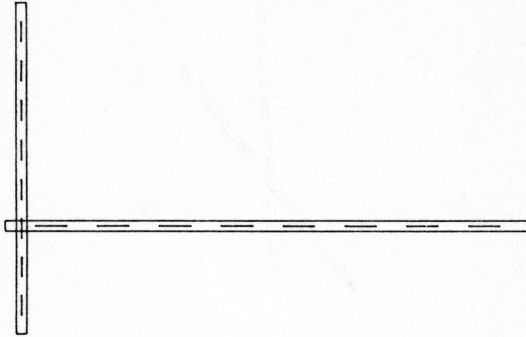

Elizabeth City, NC Elizabeth City CGAS

15055N 20632E
alt. 12

RWY 10-28 7219 X 150
RWY 01-19 4518 X 150

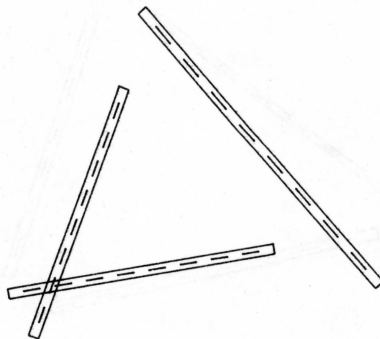

Emporia, VA

Emporia Muni

15197N 20146E
alt. 126

RWY 15-33 5009 X 100

6 - WASHINGTON

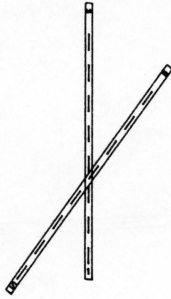

Frederick, MD

Frederick Muni

16366N 20052E
alt. 305

RWY 01-19 4000 X 100
RWY 05-23 3800 X 100

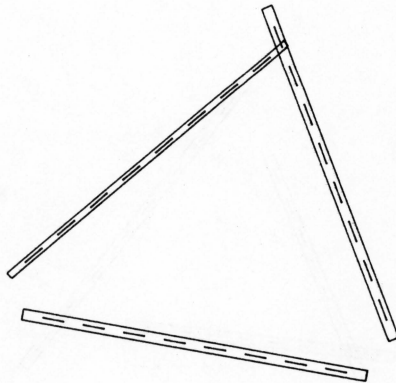

Georgetown, DE

Sussex Co.

16141N 20770E
alt. 51

RWY 04-22 5000 X 150
RWY 13-31 2325 X 50

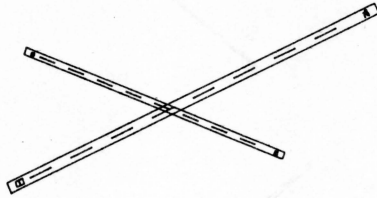

Lancaster, PA

Lancaster

16714N 20374E
alt. 403

RWY 08-26 5398 X 150

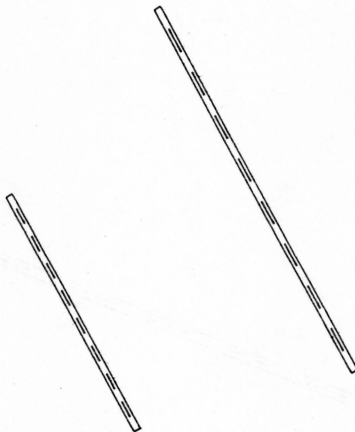

Manassas, VA

Manassas

16063N 20046E
alt. 193

RWY 16L-34R 5700 X 100
RWY 16R-34L 3703 X 100

8 - WASHINGTON

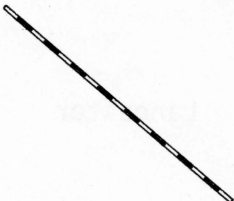

Midland, VA

Warrenton-Fauquier

16000N 19984E
alt. 325

RWY 14-32 4106 X 60
RWY 06-24 2090 X 40

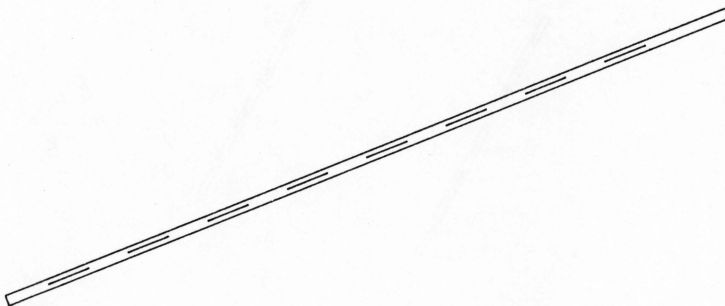

Newport News, VA

Langley AFB

15406N 20519E
alt. 11

RWY 07-25 10000 X 150

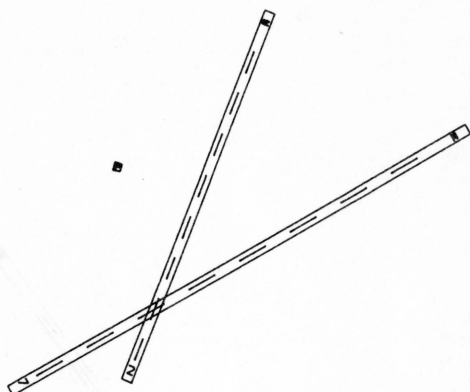

Newport News, VA

Patrick Henry Int'l

(F)

15419N 20469E
alt. 43

RWY 07-25 8003 X 150
RWY 02-20 6526 X 150

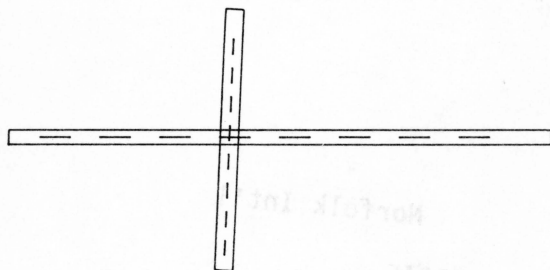

Norfolk, VA

Chambers Field

15347N 20553E
alt. 27

RWY 01-19 4300 X 250
RWY 10-28 8350 X 200

10 - WASHINGTON

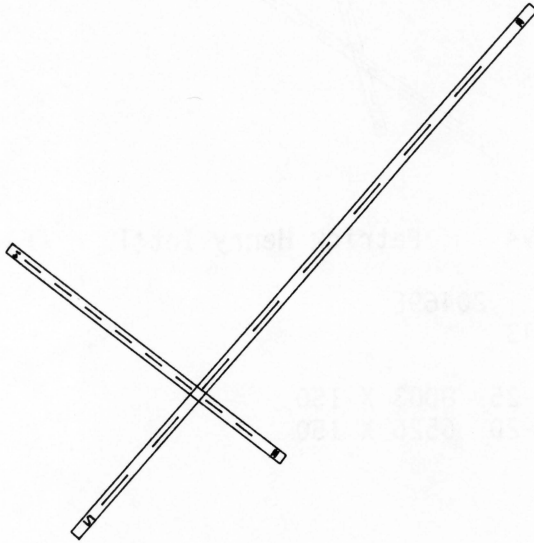

Norfolk, VA

Norfolk Int'l

15333N 20584E
alt. 27

RWY 05-23 9000 X 150
RWY 14-32 4876 X 150

ILS 23
Frequency 109.1
Heading 227 degrees
Altitude 1700 ft. @ 5.0 DME

Orange, VA

Orange Co

15840N 19878E
alt. 454

RWY 07-25 3200 X 75

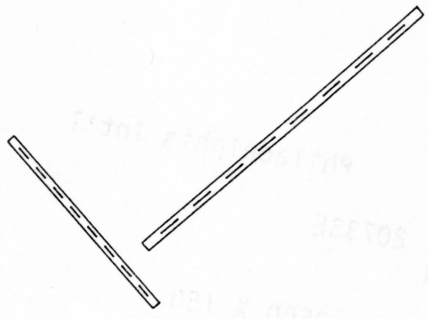
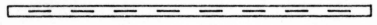

Petersburg, VA

Petersburg

Muni

15398N 20117E
alt. 194

RWY 05-23 5000 X 150
RWY 14-32 3060 X 50

12 - WASHINGTON

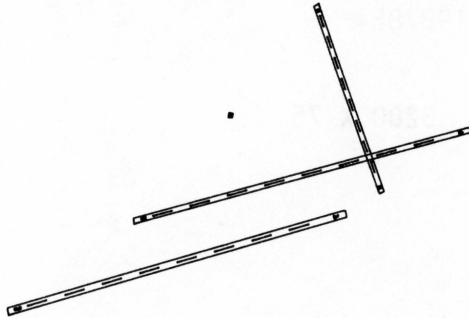

Philadelphia, PA Philadelphia Int'l (F)

16651N 20733E
alt. 21

RWY 09L-27R 9500 X 150
RWY 09R-27L 10500 X 200
RWY 17-35 5460 X 150

ILS 9R
Frequency: 109.3
Heading: 85 degrees
Altitude: 1856 ft. @ LOM

ATIS 133.40

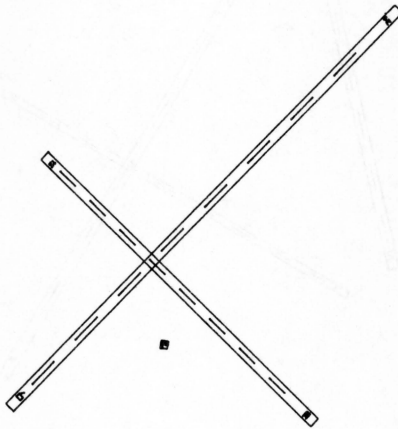

Philadelphia, PA Northeast Philadelphia (F)

16751N 20801E
alt. 121

RWY 06-24 7000 X 150
RWY 15-33 5000 X 150

14 - WASHINGTON

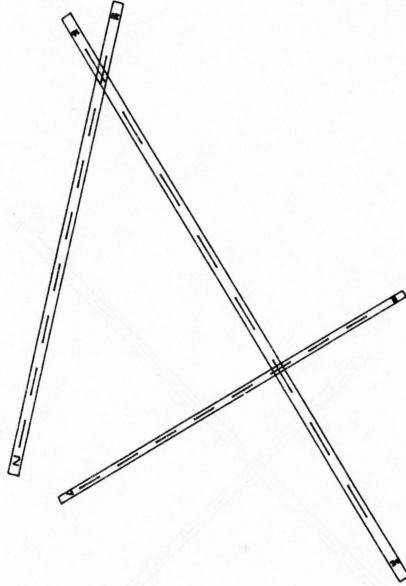

Richmond, VA

Byrd Int'l

15549N 20169E
alt. 168

RWY 16-34 8999 X 150
RWY 02-20 6607 X 150
RWY 07-25 5316 X 100

ILS 16
Frequency: 110.7
Heading: 156 degrees
Altitude: 2461 ft. @ LOM

ATIS 119.15

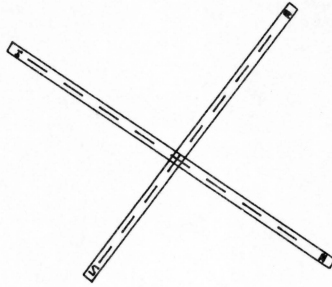

Salisbury, MD

Salisbury - Wicomico Co

15985N 20741E
alt. 51

RWY 05-23 5000 X 150
RWY 14-32 5500 X 150

ILS 32
Frequency: 108.7
Heading: 316 degrees
Altitude: 1953 ft. @ LOM

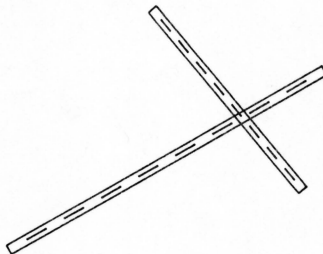

Suffolk, VA

Suffolk

15226N 20456E
alt. 72

RWY 07-25 5000 X 100
RWY 15-33 3250 X 150

16 - WASHINGTON

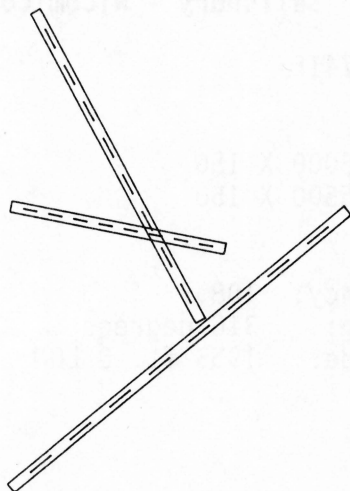

Trenton, NJ

Mercer Co.

16849N 20854E
alt. 213

RWY 06-24 6006 X 150
RWY 16-34 4800 X 150
RWY 11-29 2999 X 150

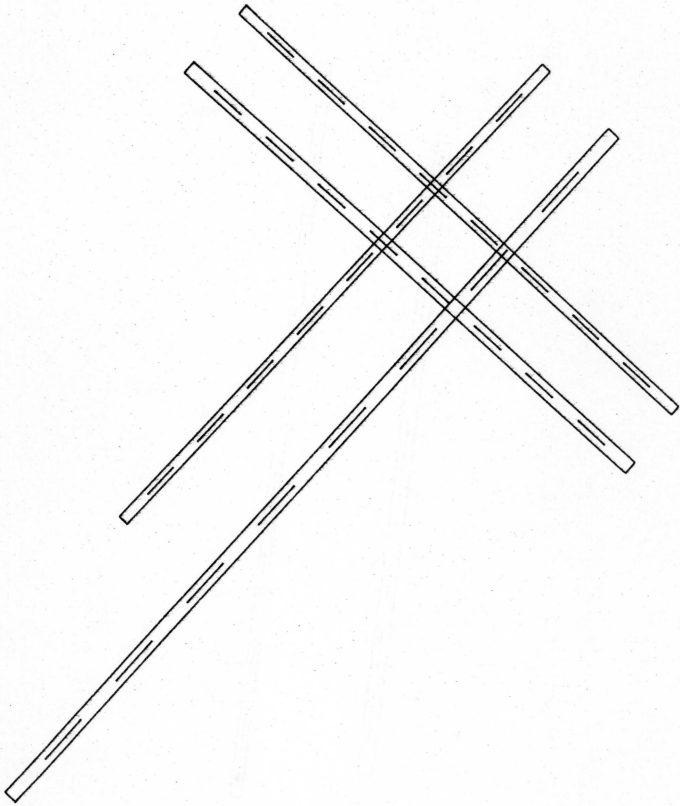

Virginia Beach, VA Oceana NAS

15307N 20649E
alt. 22

RWY 05L-23R	8000 X 150
RWY 05R-23L	12000 X 200
RWY 14L-32R	8000 X 150
RWY 14R-32L	8000 X 200

18 - WASHINGTON

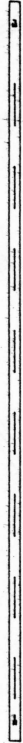
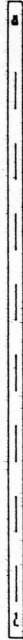

Washington, DC

Andrews AFB

16127N 20255E
alt. 281

RWY 01L-19R 9300 X 200
RWY 01R-19L 9755 X 150

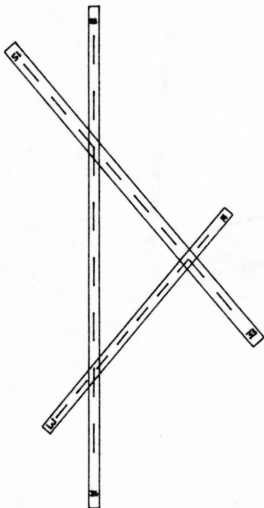

Washington, DC

Washington Nat'l

16135N 20192E
alt. 16

RWY 03-21	4905	X	150
RWY 15-33	5189	X	200
RWY 18-36	6869	X	150

20 - WASHINGTON

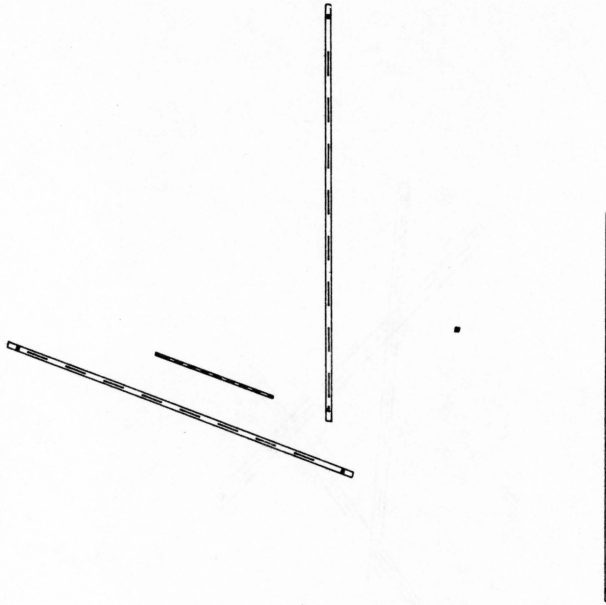

Washington, DC Dulles Int'l (F)

16163N 20055E
alt. 313

RWY 01L-19R 11501 X 150
RWY 01R-19L 11500 X 150
RWY 11L-29R 3080 X 75
RWY 12-30 10001 X 150

ILS 1R
Frequency: 110.1
Heading: 10 degrees
Altitude: 1847 ft. @ LOM

ATIS 134.85

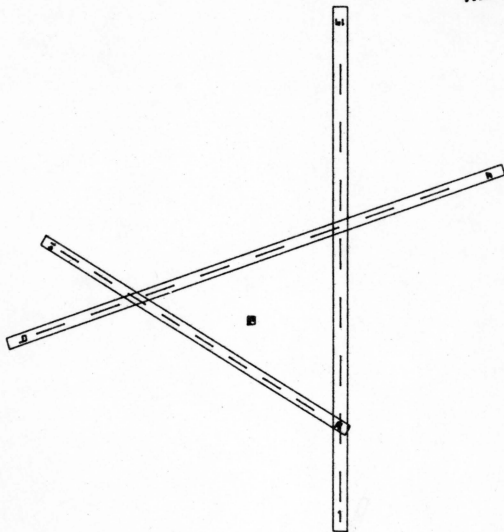

Wilmington, DE

Greater Wilmington - New Castle Co (F)

16552N 20627E
alt. 80

RWY 01-19	7002 X 200
RWY 09-27	7165 X 150
RWY 14-32	5004 X 150



Woodbridge, VA

Woodbridge

16058N 20109E
alt. 276

RWY 01-19 2250 X 45

22 - WASHINGTON

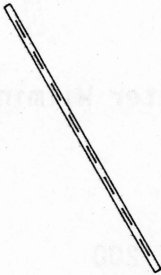

York, PA

York

16601N 20199E
alt. 486

RWY 16-34 4190 X 100

Andrews AFB (VOR)

16126N 20255E
freq. 113.1

Armel (VOR)

16157N 20047E
freq. 113.5

Atlantic City (VOR)

16506N 20983E
freq. 108.6

Baltimore (VOR)

16292N 20302E
freq. 115.1

Brooke (VOR)

15904N 20116E
freq. 111.8

Cape Charles (VOR)

15536N 20630E
freq. 112.2

Casanova (VOR)

16014N 19928E
freq. 116.3

Cedar Lake (VOR)

16522N 20848E
freq. 115.2

24 - WASHINGTON

Cofield (VOR)

15079N 20382E
freq. 114.4

Coyle (VOR)

16666N 21009E
freq. 113.4

Dupont (VOR)

16552N 20627E
freq. 114

Elizabeth City (VOR)

15053N 20629E
freq. 112.5

Flat Rock (VOR)

15537N 19995E
freq. 113.3

Franklin (VOR)

15219N 20317E
freq. 110.6

Frederick (VOR)

16366N 20054E
freq. 109

Gordonsville (VOR)

15734N 19859E
freq. 115.6

Hagerstown (VOR)

16469N 19881E
freq. 109.8

Harrisburg (VOR)

16736N 20130E
freq. 112.5

Hopewell (VOR)

15479N 20248E
freq. 112

Kenton (VOR)

16366N 20684E
freq. 111.4

Lancaster (VOR)

16715N 20377E
freq. 117.3

Lawrenceville (VOR)

15228N 20003E
freq. 112.9

Martinsburg (VOR)

16335N 19898E
freq. 112.1

Middle River (VOR)

16368N 20376E
freq. 116.6

26 - WASHINGTON

Modena (VOR)

16652N 20592E
freq. 113.2

Norfolk (VOR)

15332N 20585E
freq. 116.9

Patuxent (VOR)

15922N 20440E
freq. 117.6

Pottstown (VOR)

16787N 20612E
freq. 116.5

Richmond (VOR)

15549N 20169E
freq. 114.1

Salisbury (VOR)

15987N 20738E
freq. 114.5

Sea Isle (VOR)

16339N 20931E
freq. 114.8

Shawnee (VOR)

16220N 19811E
freq. 115.3

Tar River (VOR)

14849N 20142E
freq. 117.8

Washington (VOR)

16139N 20194E
freq. 111

Waterloo (VOR)

16199N 20810E
freq. 112.6

Westminster (VOR)

16416N 20182E
freq. 117.9

Woodstown (VOR)

16548N 20731E
freq. 112.8

28 - WASHINGTON

Amdt 3

ILS RWY 33L

AL-804 (FAA)

BALTIMORE-WASHINGTON INTL (BWI)
BALTIMORE, MARYLAND

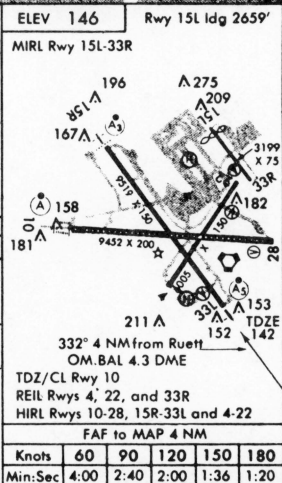
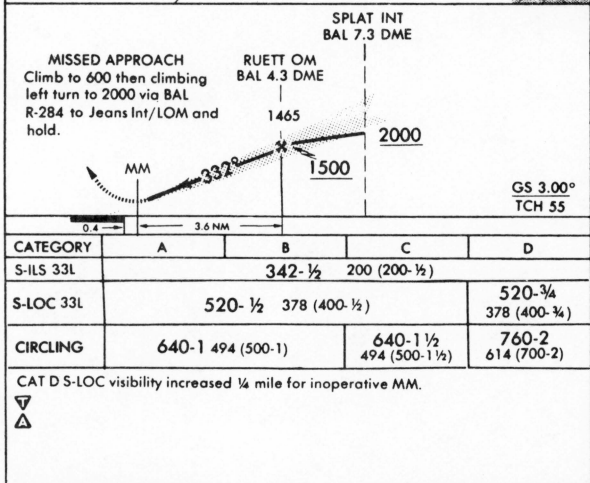
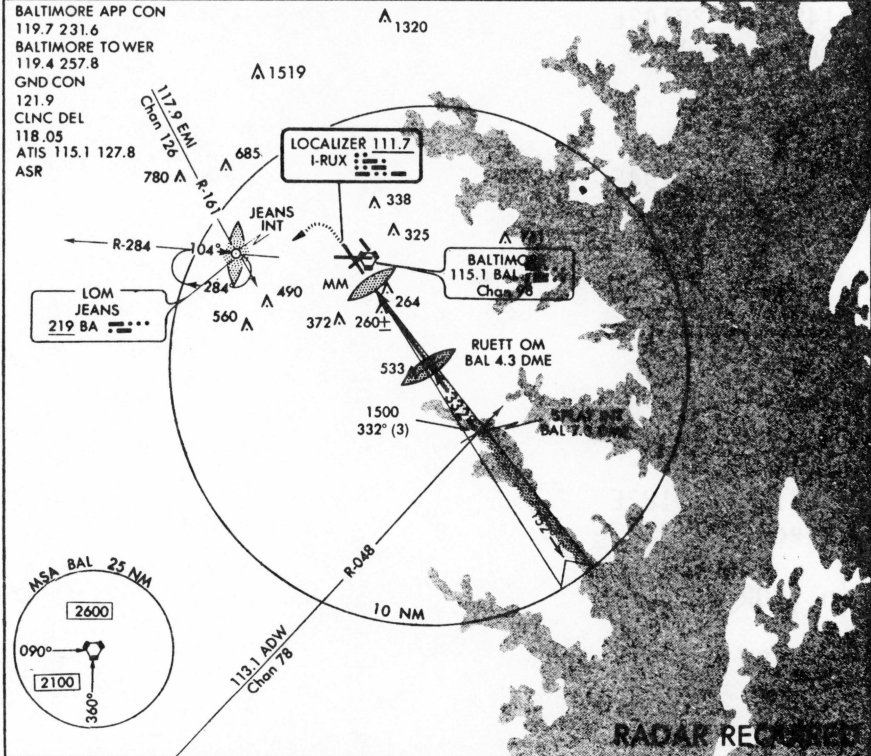

ILS RWY 33L

39°10'N-76°40'W

BALTIMORE, MARYLAND
BALTIMORE-WASHINGTON INTL (BWI)

Amdt 4
ILS RWY 23

NORFOLK INTERNATIONAL (ORF)
NORFOLK, VIRGINIA

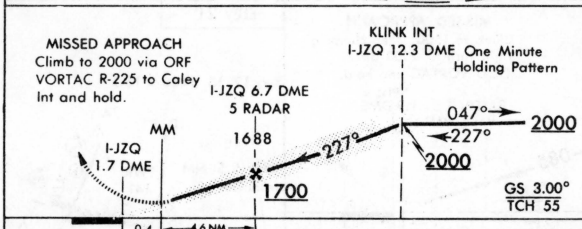
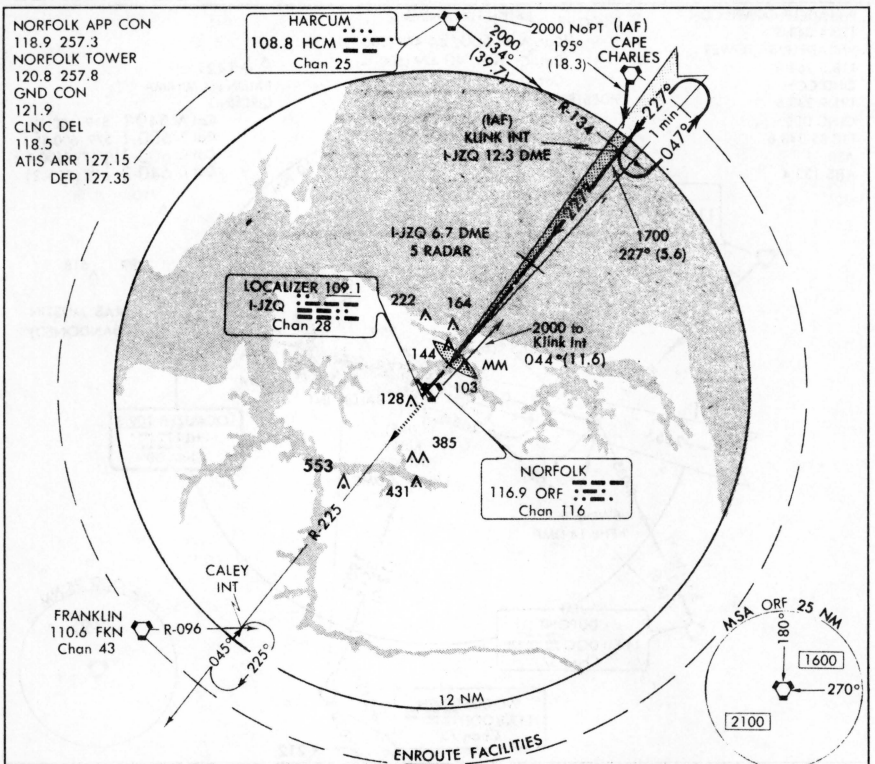

CATEGORY	A	B	C	D
S-ILS 23		321-¾	295 (300-¾)	
S-LOC 23		400-¾	374 (400-¾)	
CIRCLING	460-1 433 (500-1)	480-1 453 (500-1)	540-1½ 513 (600-1½)	580-2 553 (600-2)

DME or radar required.
Inoperative table does not apply.
S-LOC Cats. A, B, C, increase visibilities ¼ mile, Cat D ½ mile, for inoperative MALSR.
S-LOC Cat. D increase visibility ¼ mile for inoperative MM.

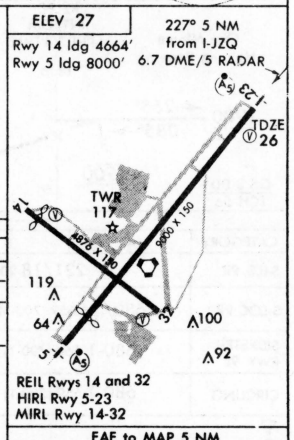

FAF to MAP 5 NM

Knots	60	90	120	150	180
Min:Sec	5:00	3:20	2:30	2:00	1:40

ILS RWY 23

36°54'N - 76°12'W

NORFOLK, VIRGINIA
NORFOLK INTERNATIONAL (ORF)

Amdt 5
ILS RWY 9R

AL-320 (FAA)

PHILADELPHIA INTERNATIONAL (PHL)
PHILADELPHIA, PENNSYLVANIA

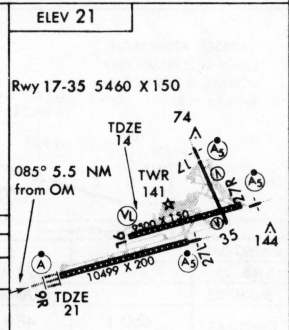
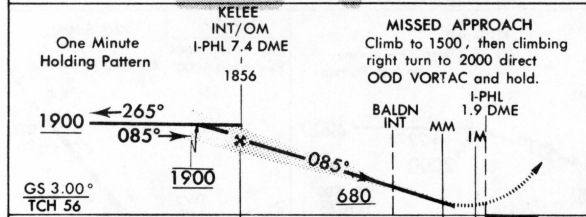
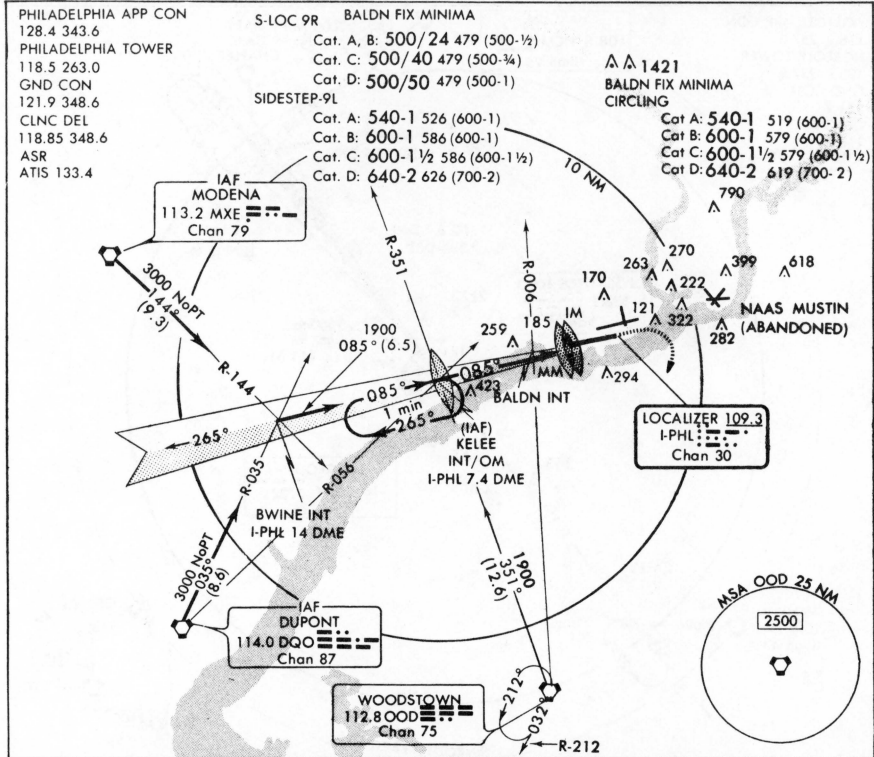

CATEGORY	A	B	C	D
S-ILS 9R	221/18 200 (200-1/2)			221/20 200 (200-1/2)
S-LOC 9R	680/24 659 (700-1/2)	680/60 659 (700-1 1/4)		680-1 1/2 659 (700-1 1/2)
SIDESTEP RWY 9L	680-1 666 (700-1)	680-1 3/4 666 (700-1 3/4)		680-2 666 (700-2)
CIRCLING	680-1 659 (700-1)	680-1 3/4 659 (700-1 3/4)		680-2 659 (700-2)

REIL Rwys 9L and 35
TDZ/CL Rwy 9R
HIRL Rwys 9L-27R, 9R-27L and 17-35

FAF to MAP 5.5 NM					
Knots	60	90	120	150	180
Min:Sec	5:30	3:40	2:45	2:12	1:50

ILS RWY 9R

39°52'N - 75°15'W

PHILADELPHIA, PENNSYLVANIA
PHILADELPHIA INTERNATIONAL (PHL)

Amdt 6

ILS RWY 16

AL-347 (FAA)

RICHMOND INTL (BYRD FIELD) (RIC)
RICHMOND, VIRGINIA

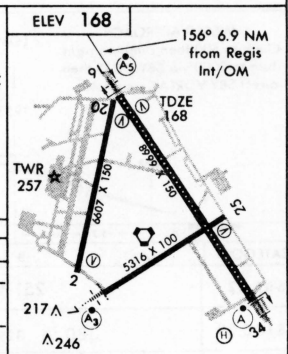
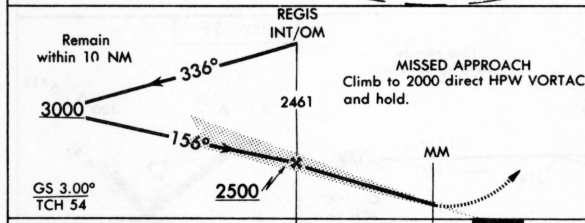
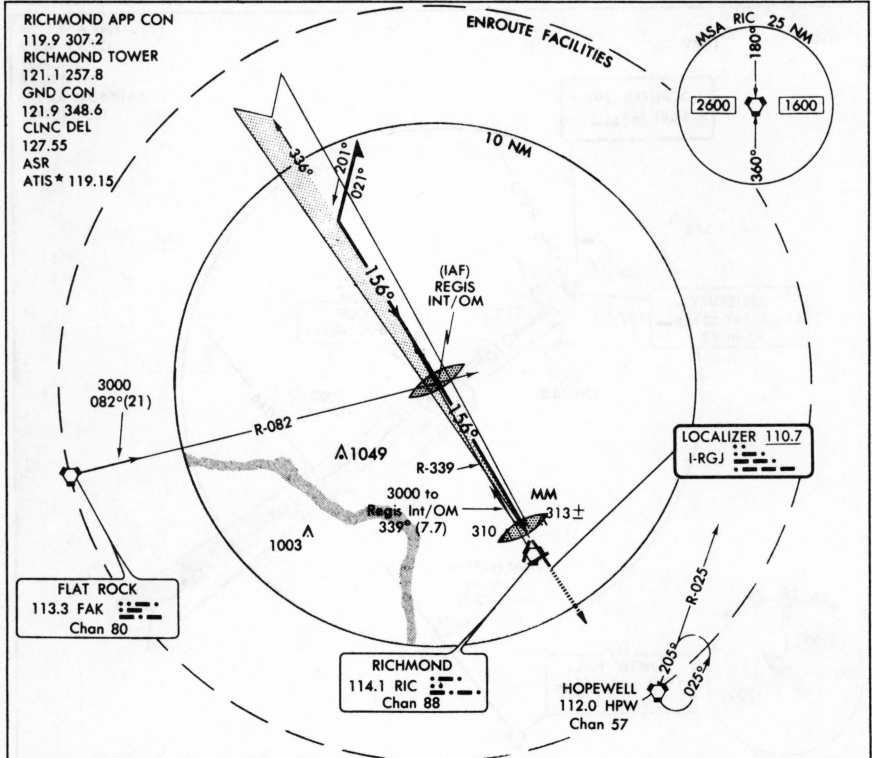

CATEGORY	A	B	C	D
S-ILS 16	368/24 200 (200-½)			
S-LOC 16	740/24	572 (600-½)	740/50 572 (600-1)	740/60 572 (600-1¼)
CIRCLING	740-1	572 (600-1)	740-1½ 572 (600-1½)	740-2 572 (600-2)

FAF to MAP 6.9 NM					
Knots	60	90	120	150	180
Min:Sec	6:54	4:36	3:27	2:46	2:18

ILS RWY 16

37°30'N - 77°19'W

RICHMOND, VIRGINIA
RICHMOND INTL (BYRD FIELD) (RIC)

32 - WASHINGTON

Amdt 4

ILS RWY 32

SALISBURY-WICOMICO COUNTY REGIONAL (SBY)
AL-977 (FAA)

SALISBURY, MARYLAND

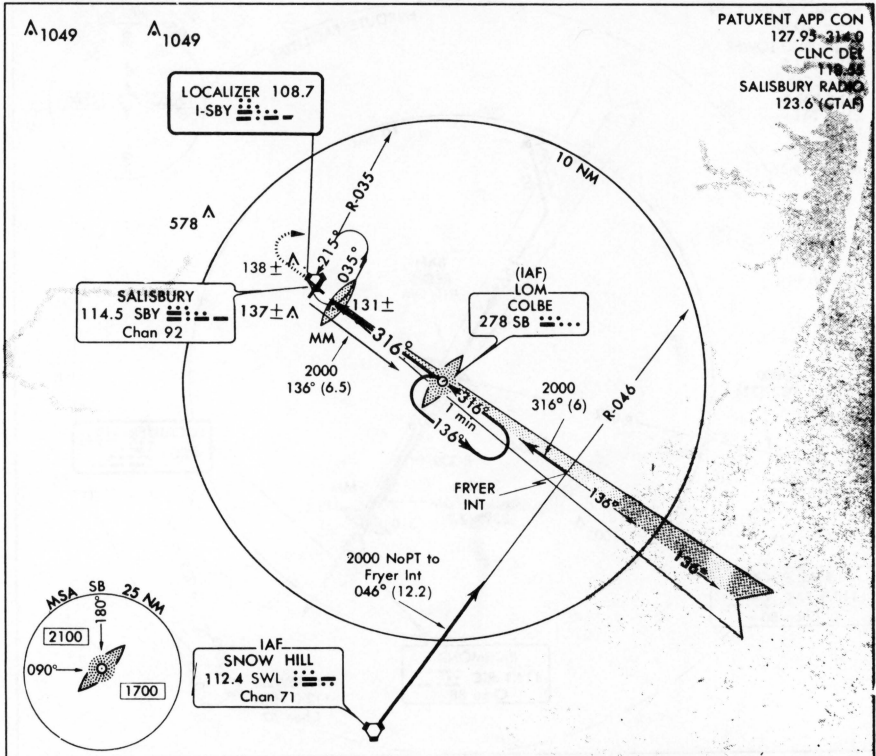

PATUXENT APP CON
127.95-316.0
CLNC DEL
118.55
SALISBURY RADIO
123.6 (GTAF)

MISSED APPROACH
Climb to 500 then climbing right turn to 2000 via SBY R-035 then direct SBY VORTAC and hold.

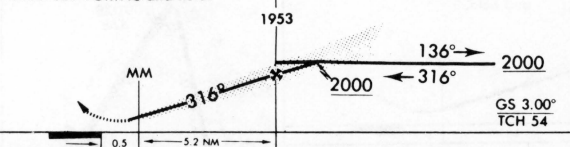

ELEV 51

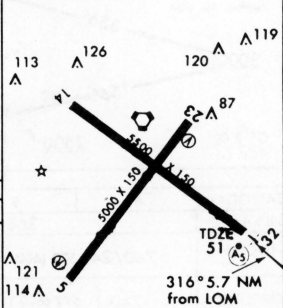

CATEGORY	A	B	C	D
S-ILS 32	251-1/2 200 (200-1/2)			
S-LOC 32	380-1/2 329 (400-1/2)		380-3/4 329 (400-3/4)	
CIRCLING	440-1	520-1	520-1 1/2	620-2
	389 (400-1)	469 (500-1)	469 (500-1 1/2)	569 (600-2)

Cat. D S-LOC visibility increased 1/4 mile for inoperative MALS or MM.

REIL Rwy 5, 14 and 23
MIRL Rwy 5-23 and 14-32

FAF to MAP 5.7 NM

Knots	60	90	120	150	180
Min:Sec	5:42	3:48	2:51	2:17	1:54

ILS RWY 32

38°20'N - 75°31'W

SALISBURY, MARYLAND

SALISBURY-WICOMICO COUNTY REGIONAL (SBY)

Amdt 17

ILS RWY 1R

AL-5100 (FAA)

WASHINGTON/DULLES INTL (IAD)
WASHINGTON, D.C.

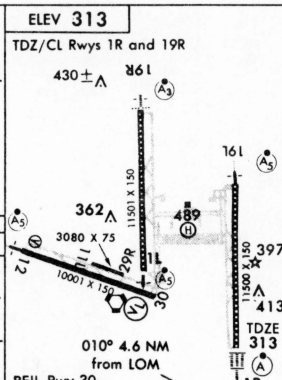
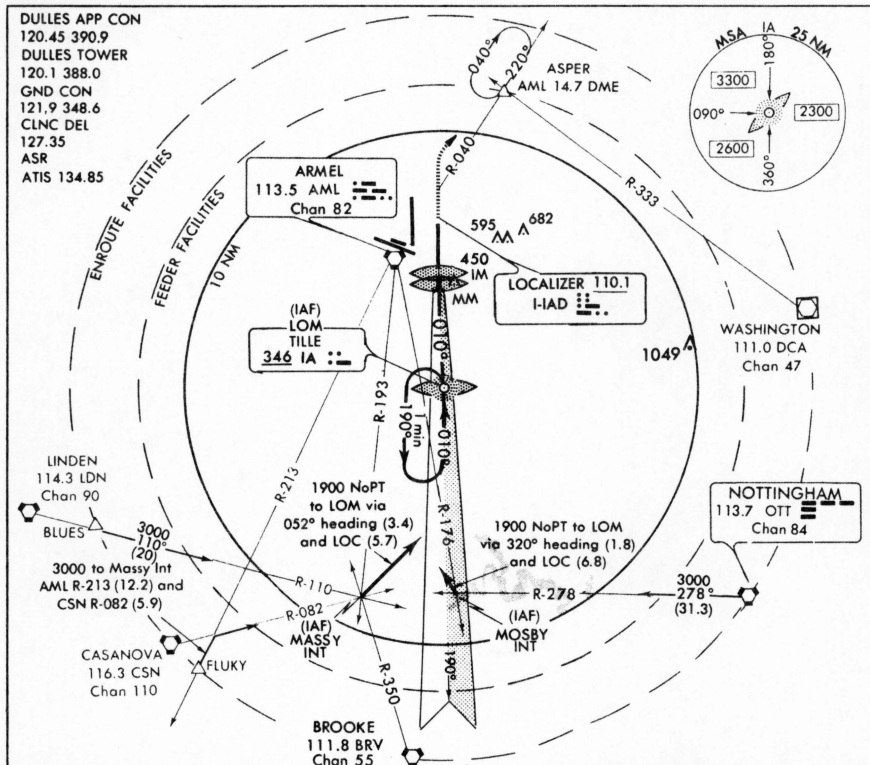

Cat. D S-LOC visibility increased to RVR 5000 for inoperative MM.

FAF to MAP 4.6 NM					
Knots	60	90	120	150	180
Min:Sec	4:36	3:04	2:18	1:50	1:32

ILS RWY 1R

38°57'N-77°27'W

WASHINGTON, D.C.
WASHINGTON/DULLES INTL (IAD)

UNITED STATES DEPARTMENT OF THE INTERIOR
BUREAU OF LAND MANAGEMENT
WASHINGTON, D. C. 20250

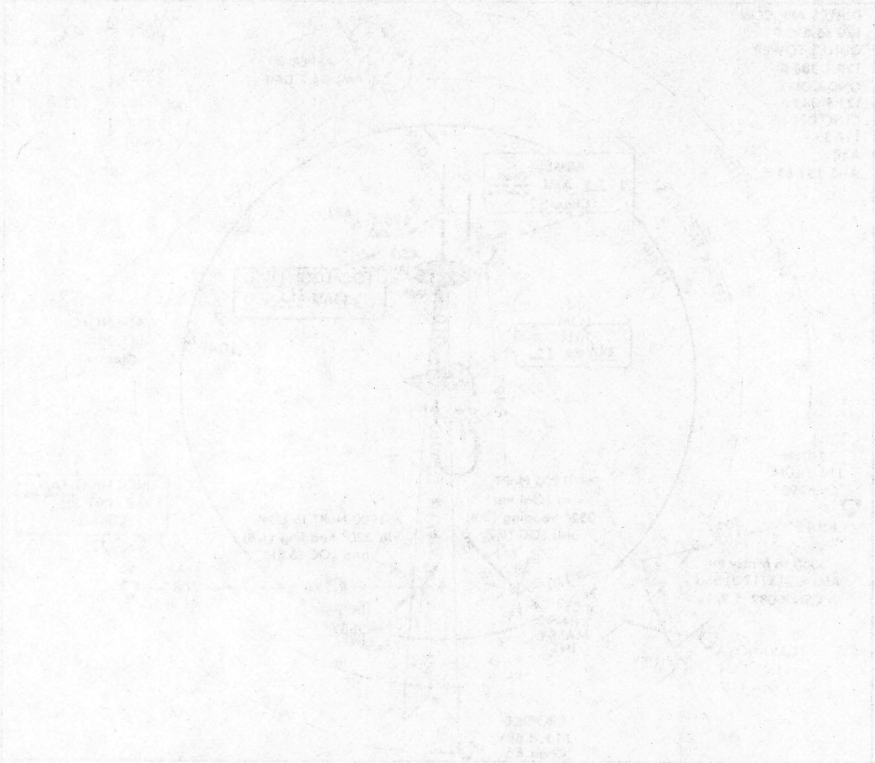

SECTION	ACRES	DATE	REMARKS
SECTION 10	10.00	1950	...
SECTION 11	10.00	1950	...
SECTION 12	10.00	1950	...
TOTAL	30.00		

UNITED STATES DEPARTMENT OF THE INTERIOR
BUREAU OF LAND MANAGEMENT
WASHINGTON, D. C. 20250



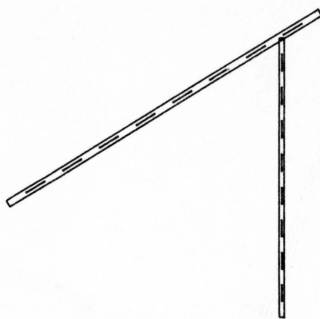

Aiken, SC

Aiken Muni

13724N 18819E
alt. 529

RWY 06-24 5000 X 100
RWY 18-36 3800 X 75



Allendale, SC

Allendale Co

13454N 18991E
alt. 160

RWY 17-35 3200 X 75

2 - CHARLOTTE

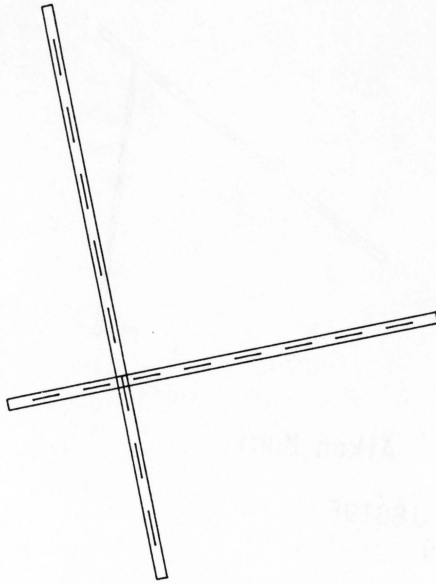

Augusta, GA

Bush Field

13599N 18729E
alt. 145

RWY 08-26 6001 X 150
RWY 17-35 8000 X 150

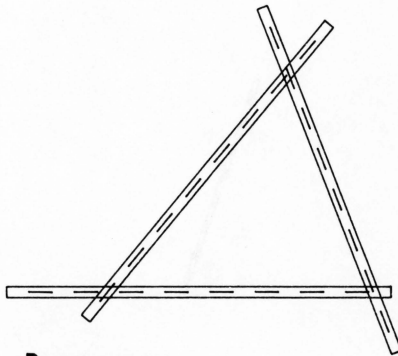

Barnwell, SC

Barnwell Co

13564N 18937E
alt. 246

RWY 04-22 5272 X 100
RWY 16-34 5118 X 100

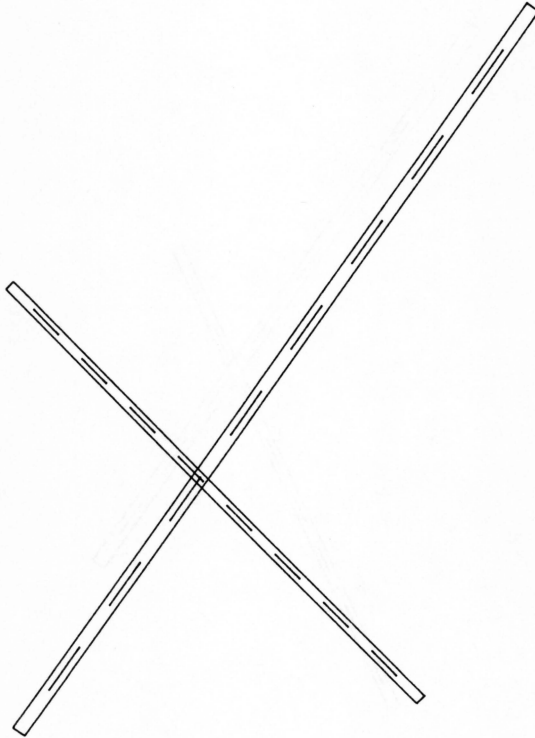

Beaufort, SC

MCAS Beaufort

13248N 19211e
alt. 38

RWY 04-22 12200 X 200
RWY 14-32 8000 X 200

4 - CHARLOTTE

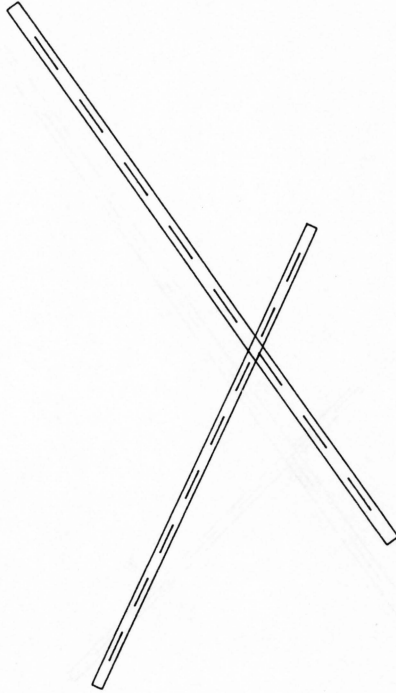

Charleston, SC

Charleston AFB/Int'l

13448N 19417E
alt. 46

RWY 03-21 7000 X 150
RWY 15-33 9001 X 200

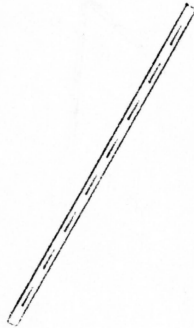
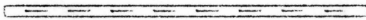

Charleston, SC

Charleston Executive

13366N 19462E
alt. 20

RWY 03-21 5000 X 150
RWY 09-27 5000 X 150

6 - CHARLOTTE

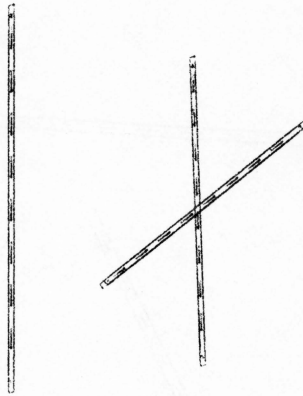

Charlotte, NC Charlotte / Douglas Int'l (F)

14427N 19030E
alt. 749

RWY 05-23 7501 X 150
RWY 18L-36R 7845 X 150
RWY 18R-36L 10000 X 150

ILS 5
Frequency: 109.5
Heading: 52 degrees
Altitude: 2087 ft. @ LOM

ATIS 121.15

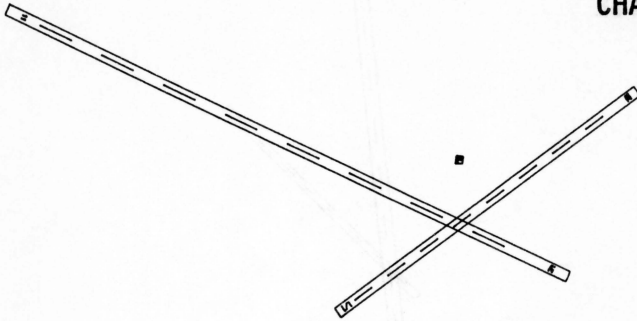

Columbia, SC Columbia Metro (F)

13876N 19005E
alt. 236

RWY 05-23 5001 X 150
RWY 11-29 8600 X 150

ATIS 120.15



Columbia, SC Conway - Horry Co

13881N 19735E
alt. 35

RWY 04-22 3710 X 60

8 - CHARLOTTE

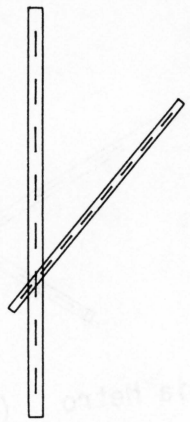

Edenton, NC

Edenton Muni

14940N 20524E
alt. 19

RWY 01-19 5600 X 200
RWY 05-23 3700 X 100

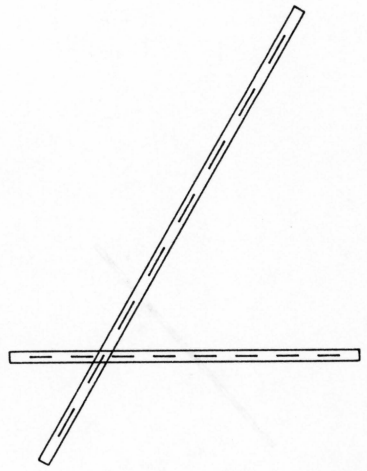

Fayetteville, NC Fayetteville Muni / Grannis Fld

14386N 19769E
alt. 190

RWY 04-22 7204 X 150
RWY 10-28 4802 X 150

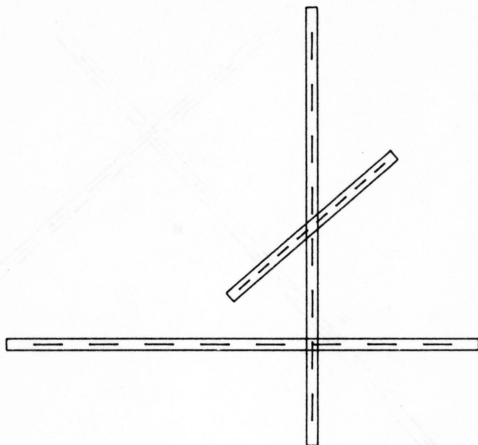

Florence, SC

Florence City-Co

14008N 19501E
alt. 147

RWY 09-27	6498 X 150
RWY 18-36	6001 X 150
RWY 05-23	2992 X 150

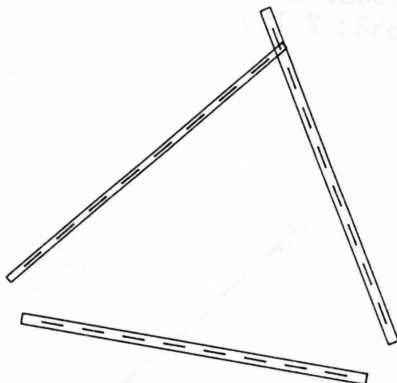

Georgetown, SC

Georgetown Co

13653N 19685E
alt. 39

RWY 05-23	5000 X 100
RWY 16-34	4930 X 150
RWY 10-28	4800 X 150

10 - CHARLOTTE

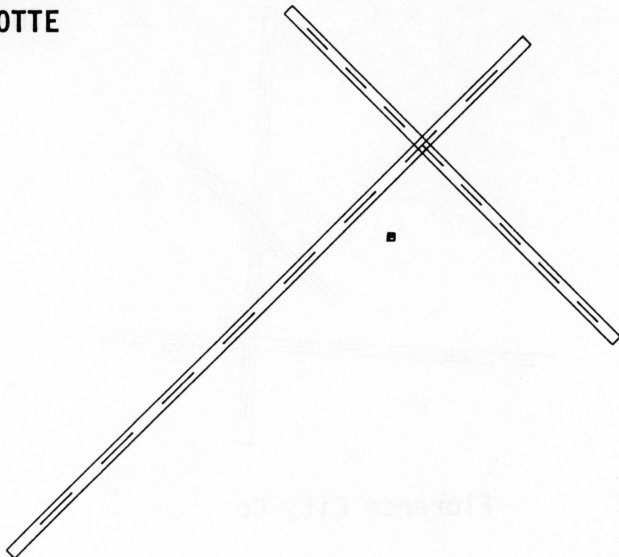

Greensboro, NC Greensboro - High Point - Winston Salem Reg'l

(F) 14829N 19358E
alt. 926

RWY 05-23 10000 X 150
RWY 14-32 6380 X 150



Kingstree, SC Williamsburg Co

13807N 19474E
alt. 68

RWY 14-32 3700 X 75

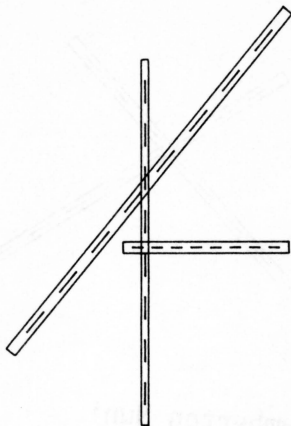

Kinston, NC

Eastern Regional

14589N 20196E
alt. 94

RWY 04-22 6000 X 150
RWY 18-36 5000 X 100
RWY 09-27 2280 X 150

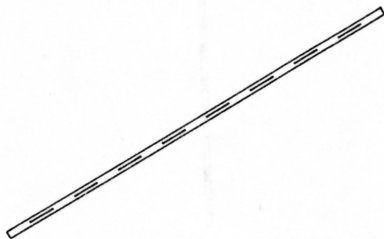

Lancaster, SC

Lancaster Co

14208N 19069E
alt. 486

RWY 06-24 6000 X 100

12 - CHARLOTTE

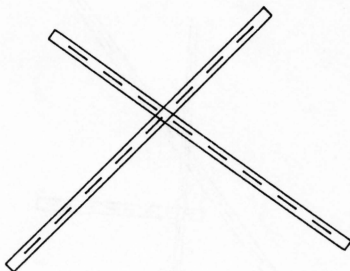

Lumberton, NC

Lumberton Muni

14214N 19717E
alt. 126

RWY 05-23 5000 X 150
RWY 13-31 5000 X 150



Manning, SC

Clarendon Co

13742N 19353E
alt. 104

RWY 01-19 3600 X 75

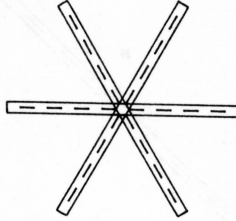

Manteo, NC

Dare Co

14923N 20819E
alt. 13

RWY 04-22 3300 X 150
RWY 16-34 3290 X 150
RWY 10-28 3180 X 150



Mocksville, NC

Twin Lakes

14733N 19180E
alt. 820

RWY 09-27 2950 X 50

14 - CHARLOTTE

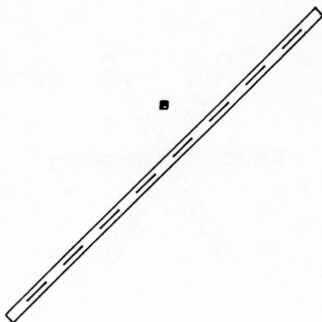

N Myrtle Beach, SC Grand Strand (F)

13885N 19876E
alt. 33

RWY 05-23 5996 X 100

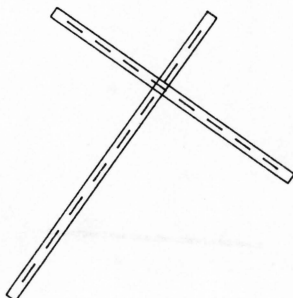

New Bern, NC

Simmons-Nott

14484N 20415E
alt. 19

RWY 04-22 4804 X 150
RWY 13-31 4000 X 150



Orangeburg, SC Orangeburg

13666N 19124E
alt. 197

RWY 04-22 4500 X 100



Plymouth, NC Plymouth Muni

14827N 20475E
alt. 39

RWY 02-20 3700 X 75

16 - CHARLOTTE

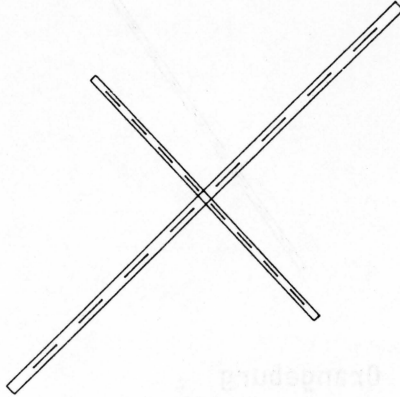

Raleigh, NC

Raleigh-Durham (F)

14765N 19769E
alt. 437

RWY 05R-23L 7500 X 150
RWY 14-32 4498 X 100



Salisbury, NC

Rowan Co

14613N 19151E
alt. 771

RWY 02-20 4200 X 100
RWY 11-29 1900 X 100

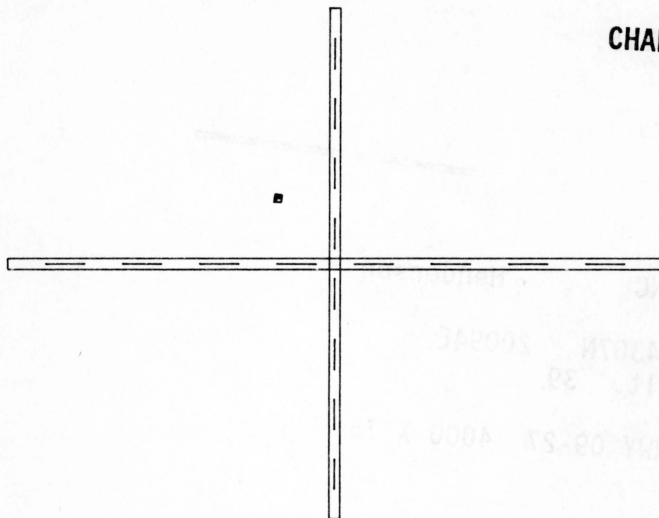

Savannah, GA

Savannah Int'l (F)

13078N 19032E
alt. 51

RWY 09-27 9003 X 150
RWY 18-36 7001 X 150

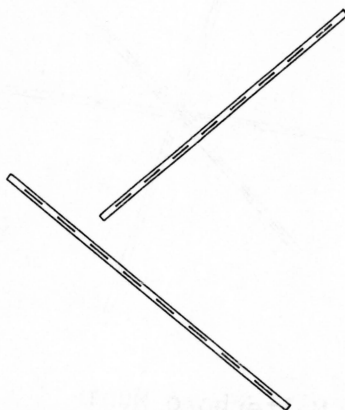

Statesboro, GA

Statesboro Muni

13224N 18838E
alt. 187

RWY 14-32 5000 X 100
RWY 05-23 4381 X 100

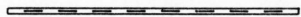

Wallace, NC

Henderson

14307N 20094E
alt. 39

RWY 09-27 4000 X 75

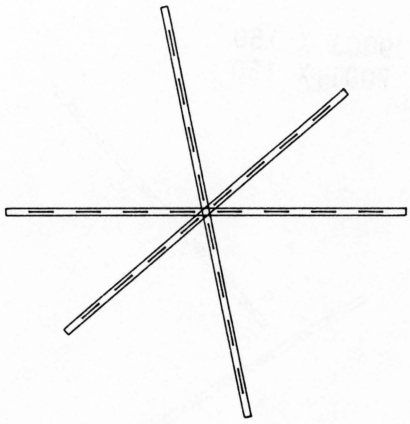

Walterboro, SC

Walterboro Muni

13441N 19222E
alt. 98

RWY 17-35 5700 X 100
RWY 09-27 5500 X 100
RWY 05-23 5150 X 100



Whiteville, NC Columbus Co

14081N 19853E
alt. 90

RWY 05-23 3700 X 75

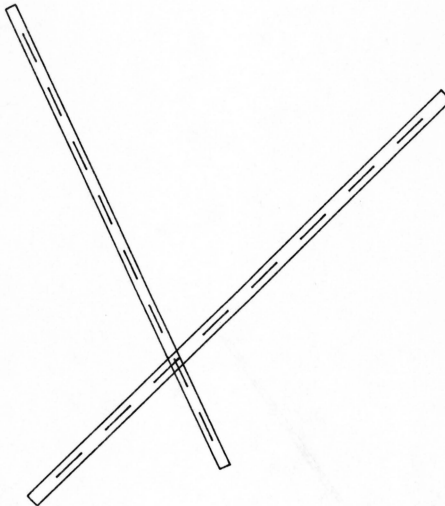

Wilmington, NC New Hanover Co

14108N 20146E
alt. 32

RWY 05-23 7999 X 200
RWY 16-34 7002 X 150

20 - CHARLOTTE

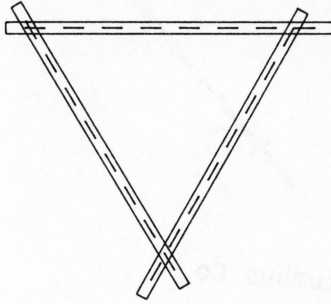

Wilson, NC

Wilson Muni

14748N 20059E
alt. 161

RWY 03-21	4500 X 150
RWY 09-27	4500 X 150
RWY 15-33	4500 X 150



Winnsboro, SC

Fairfield Co

14019N 18983E
alt. 574

RWY 04-22 3200 X 75

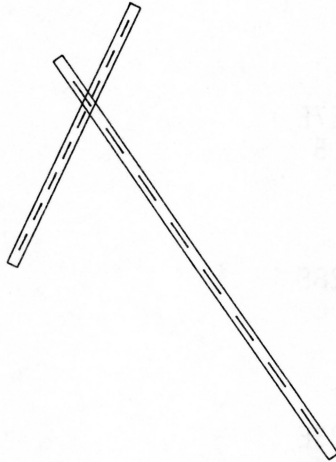

Winston Salem, NC Smith Reynolds

14839N 19258E
alt. 970

RWY 15-33 6655 X 150
RWY 03-21 3938 X 150

22 - CHARLOTTE

Allendale (VOR)

13467N 18967E
freq. 116.7

Barretts Mountain (VOR)

14703N 18907E
freq. 110.8

Charleston (VOR)

13449N 19427E
freq. 113.5

Charlotte (VOR)

14423N 19028E
freq. 110.6

Chesterfield (VOR)

14201N 19283E
freq. 108.2

Columbia (VOR)

13837N 19030E
freq. 114.7

Fayetteville (VOR)

14385N 19771E
freq. 108.8

Florence (VOR)

14038N 19518E
freq. 115.2

Fort Mill (VOR)

14330N 19033E
freq. 112.4

Grand Strand (VOR)

13886N 19869E
freq. 117.6

Greensboro (VOR)

14810N 19345E
freq. 116.2

Kinston (VOR)

14612N 20214E
freq. 109.6

New Bern (VOR)

14484N 20413E
freq. 113.6

Raleigh - Durham (VOR)

14766N 19770E
freq. 117.2

Sandhills (VOR)

14462N 19509E
freq. 111.8

Savannah (VOR)

13103N 19057E
freq. 112.7

24 - CHARLOTTE

Tar River (VOR)

14849N 20142E
freq. 117.8

Vance (VOR)

13688N 19259E
freq. 110.4

Wilmington (VOR)

14145N 20151E
freq. 117

Wright Brothers (VOR)

14900N 20845E
freq. 111.6

Amdt 30
ILS RWY 5

AL-78 (FAA)

CHARLOTTE/DOUGLAS INTL (CLT)
CHARLOTTE, NORTH CAROLINA

CHARLOTTE APP CON
125.35 257.2 180°-359°
126.15 316.7 360°-179°
CHARLOTTE TOWER
118.1 257.8
GND CON 121.9 348.6
CLNC DEL
121.4 Δ 2720
ASR
ATIS 121.15

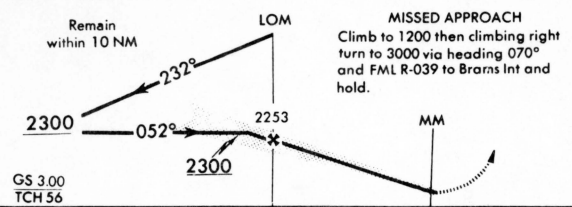
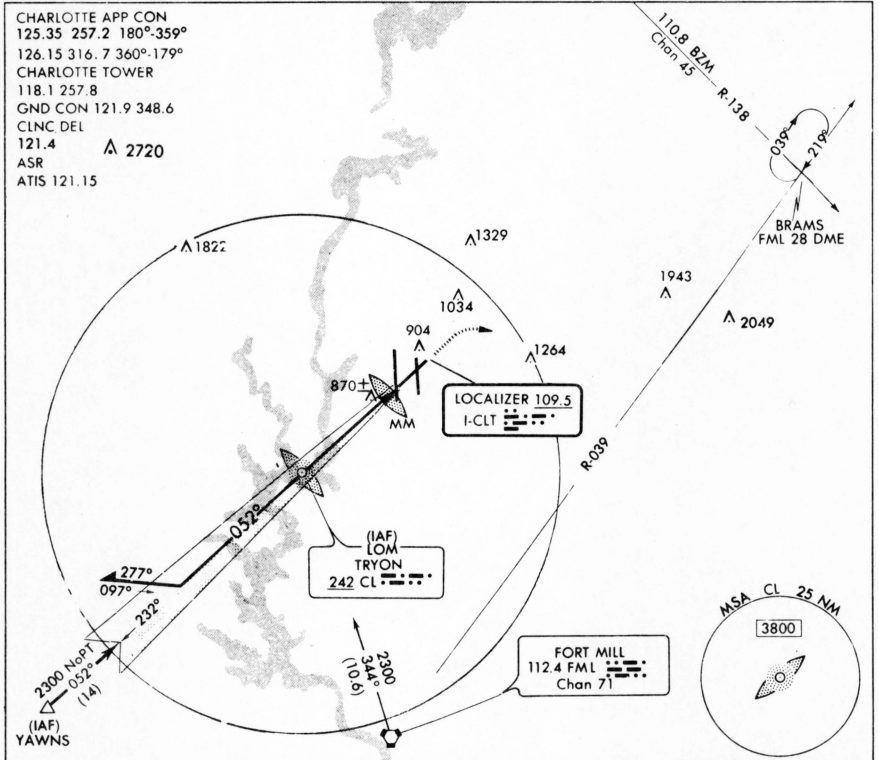

CATEGORY	A	B	C	D
S-ILS 5		916/24	200 (200-1/2)	
S-LOC 5	1120/24	404 (400-1/2)	1120/40	404 (400-3/4)
CIRCLING	1220-1	471 (500-1)	1220-1 1/2 471 (500-1 1/2)	1300-2 551 (600-2)

Cat. D S-LOC visibility increased to RVR 5000 for inoperative MM.

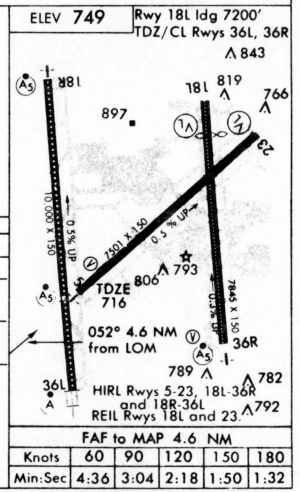

ILS RWY 5

35° 13' N-80° 57' W

CHARLOTTE, NORTH CAROLINA
CHARLOTTE/DOUGLAS INTL (CLT)

CHARLOTTE - 52

112 444 2

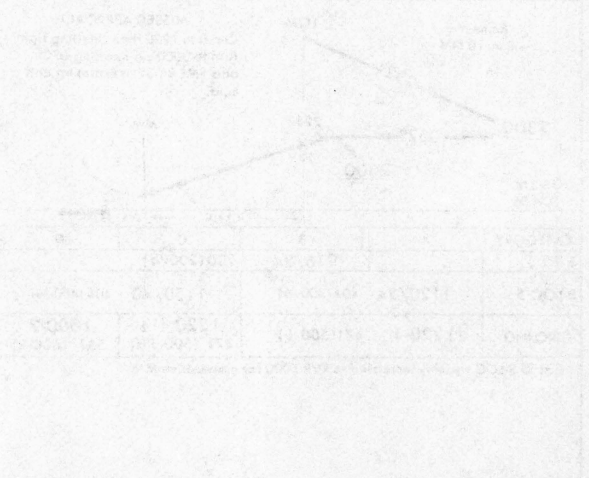
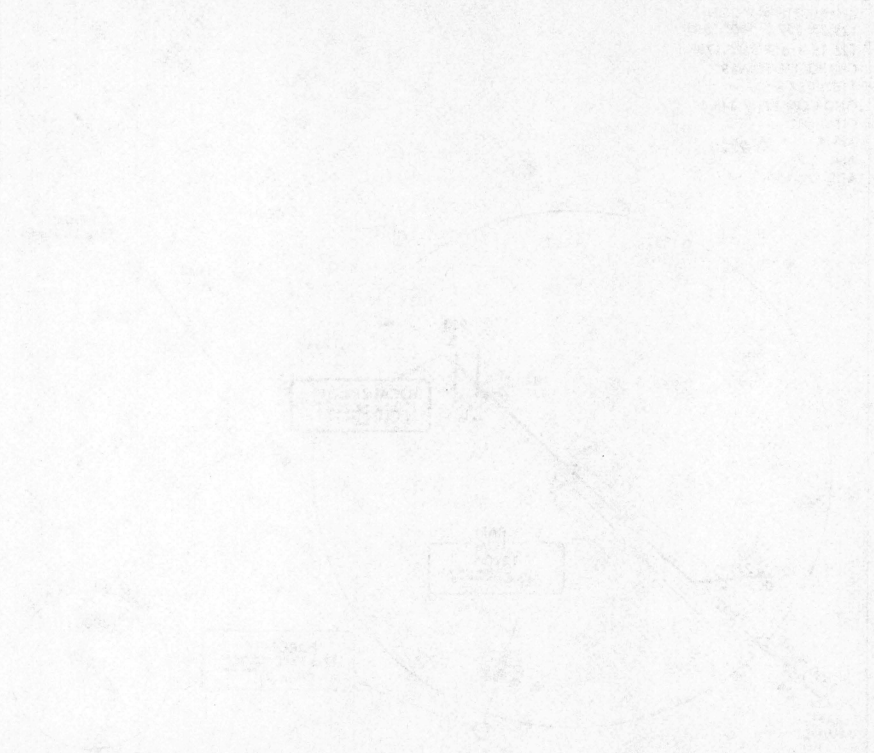

CHARLOTTE - 52

112 444 2

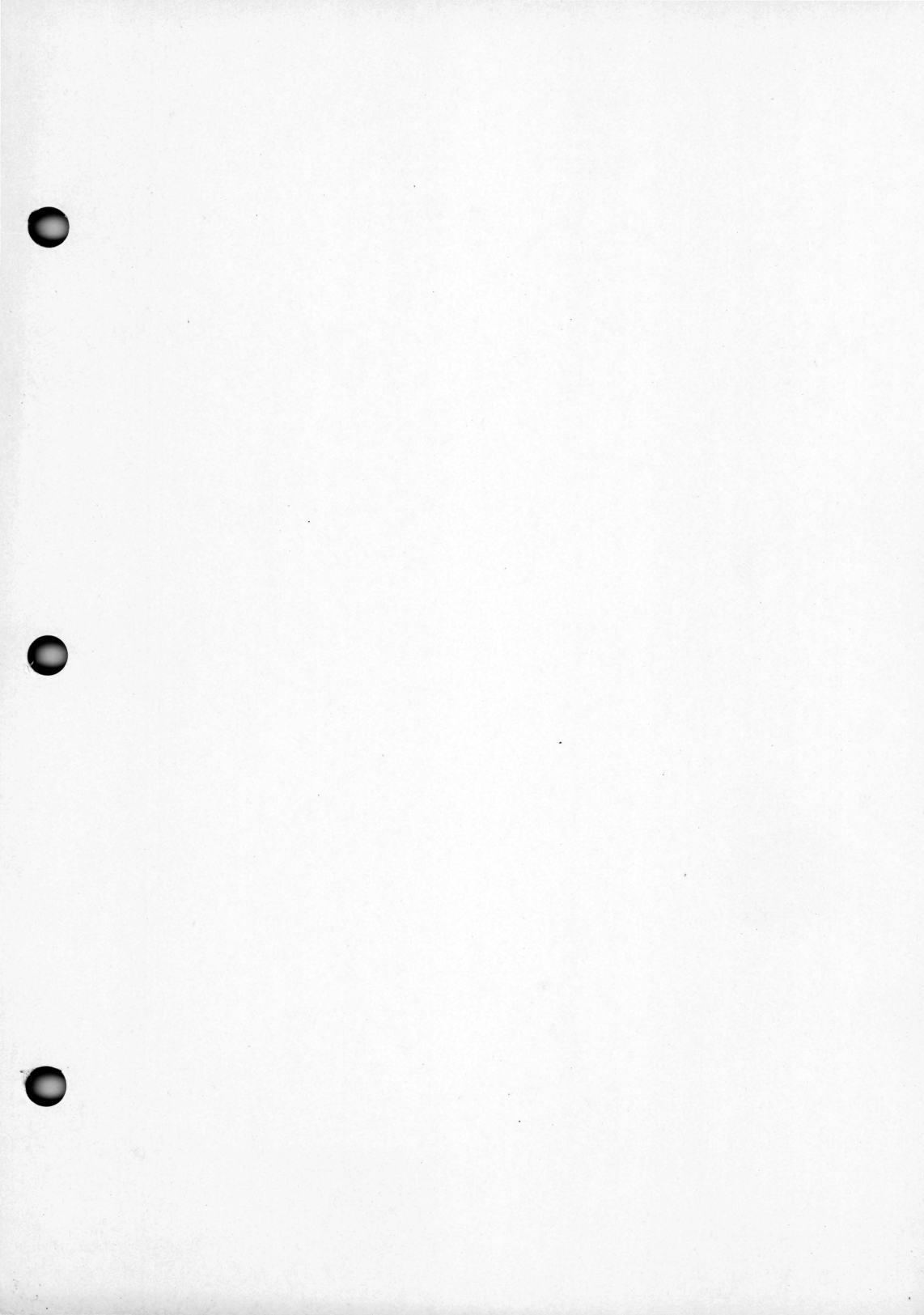



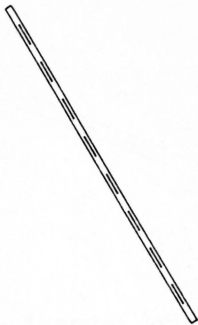

Alma

Bacon Co.

12789N 18598E
alt. 201

RWY 15-33 5000 x 100

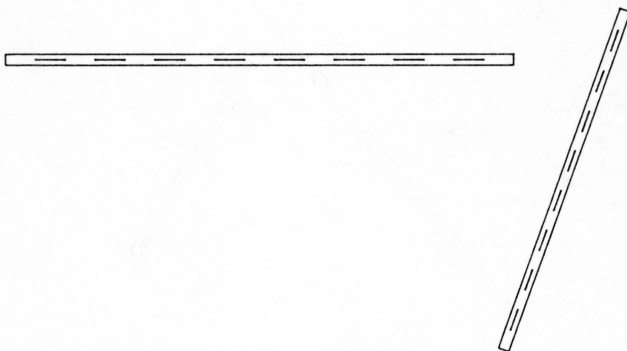

Brooksville Hernando Co

11461N 18702E
alt. 76

RWY 9-27 7000 x 150
RWY 2-20 5000 x 150

2 - JACKSONVILLE

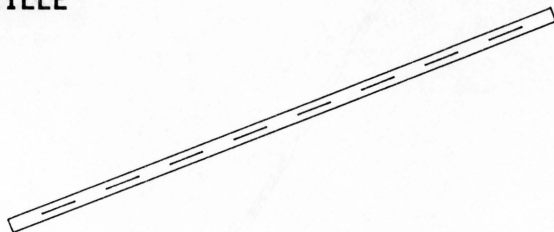

Brunswick

Glynco Jetport

12696N 18990E
alt. 26

RWY 7-25

8001 X 150

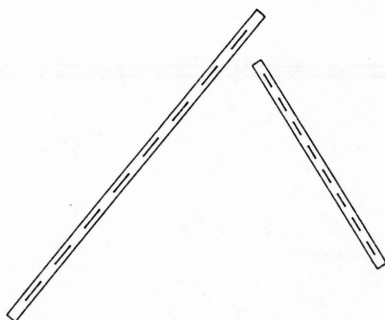

Brunswick

Malcom McKinnon

12650N 19020E
alt. 20

RWY 4-22

5421 x 150

RWY 15-33

3313 x 100



Camilla - Mitchell Co

12610N 17964E
alt. 171

RWY 8-26 3200 x 60

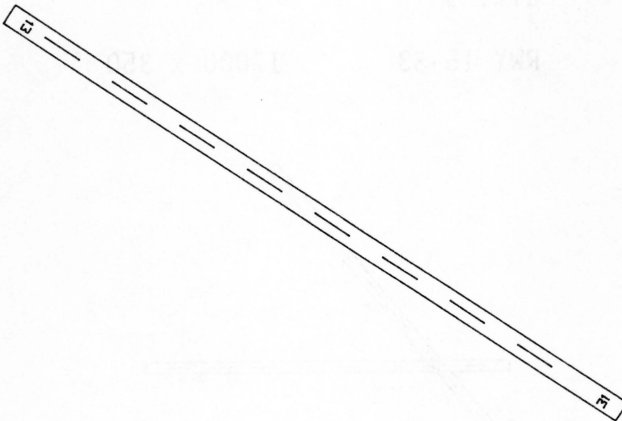

Cape Canaveral

Cape Canaveral Skid Pad

11519N 19408E
alt. 10

RWY 13-31 10000 x 300

4 - JACKSONVILLE

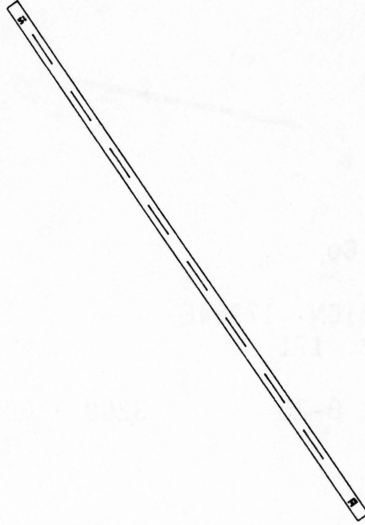

Cape Canaveral

Shuttle Landing Facility

11578N 19355E
alt. 9

RWY 15-33

17000 x 350

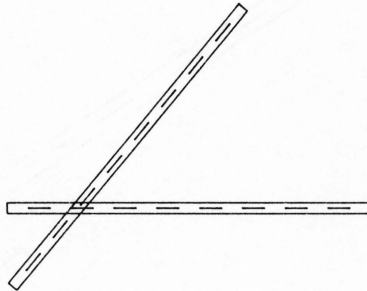

Cordele

Crisp Co - Cordelle

12957N 18119E
alt. 308

RWY 4-22

5000 x 100

RWY 9-27

5000 x 100

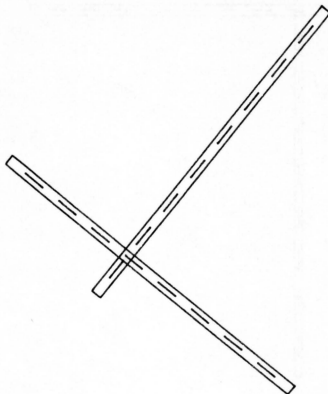

Cross City

Cross City

11950N 18425E
alt. 42

RWY 4-22	5000 x 150
RWY 13-31	5000 x 150

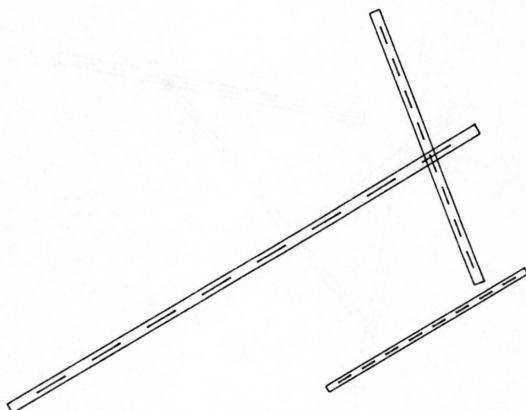

Daytona Beach

Daytona Beach Regional

11808N 19210E
alt. 35

RWY 6L-24R	7500 x 150
RWY 16-34	4000 x 150
RWY 6R-24L	3197 x 100

6 - JACKSONVILLE

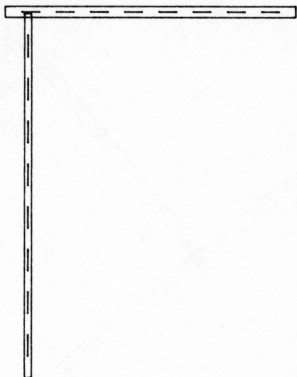

Donalsonville

Donalsonville Muni

12511N 17733E
alt. 160

RWY 18-36	5000 x 100
RWY 9-27	4000 x 150

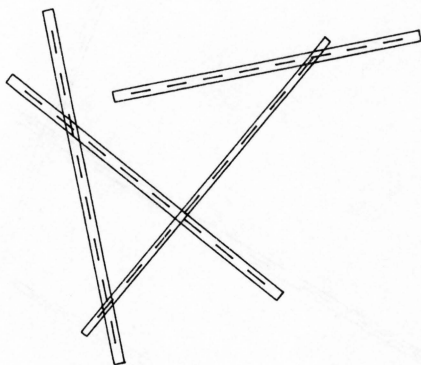

Fernandina Beach

Fernandina Beach Muni

12414N 19014E
alt. 15

RWY 4-22	5350 x 100
RWY 13-31	5150 x 150
RWY 8-26	5000 x 150
RWY 17-35	5000 x 150

JACKSONVILLE - 7



Fitzgerald Fitzgerald Muni

12838N 18314E
alt. 365

RWY 1-19

5000 x 100

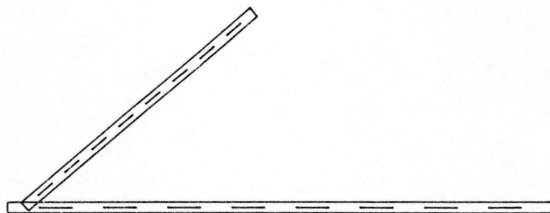

Gainesville

Gainesville Regional

11993N 18737E
alt. 152

RWY 10-28
RWY 6-24

7503 x 150
4147 x 100

8 - JACKSONVILLE



Hazelhurst

Hazelhurst

12937N 18537E
alt. 255

RWY 14-32

4500 x 75

10 - JACKSONVILLE

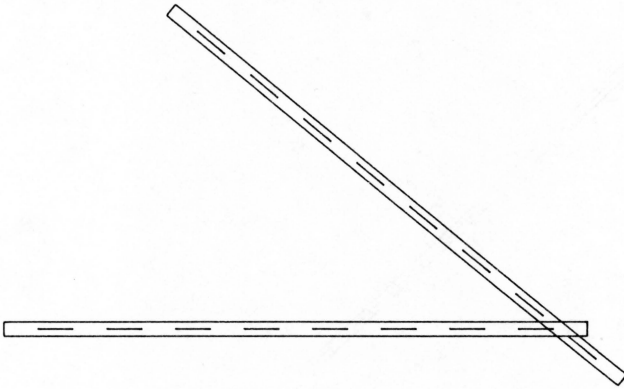

Jacksonville

Jacksonville NAS

12247N 18942E
alt. 22

RWY 9-27	8000 x 200
RWY 13-31	5977 x 200

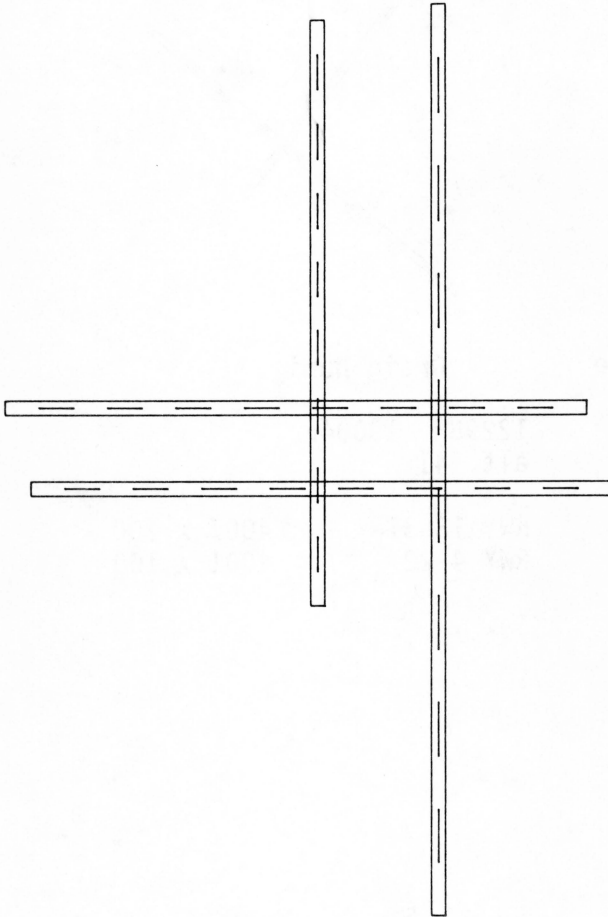

Jacksonville

Cecil Field NAS

12238N 18861E
alt. 80

RWY 18L-36R	12500 x 200
RWY 9L-27R	8000 x 200
RWY 9R-27L	8000 x 200
RWY 18R-36L	8000 x 200

12 - JACKSONVILLE

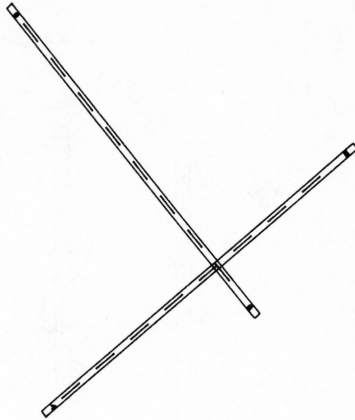

Jacksonville

Craig Muni

12298N 19004E
alt. 41

RWY 13-31	4007 x 100
RWY 4-22	4001 x 100

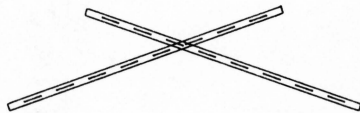

Jacksonville

Herlong

12260N 18892E
alt. 87

RWY 7-25	4000 x 100
RWY 11-29	4000 x 100



Jesup - Wayne Co.

12809N 18828E
alt. 108

RWY 10-28 3800 x 75

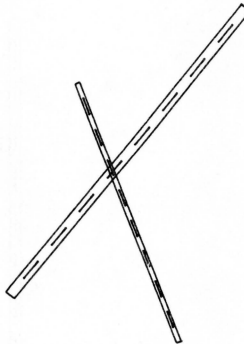

Moultrie

Moultrie Muni

12564N 18129E
alt. 294

RWY 4-22 5127 x 150
RWY 16-34 3878 x 75

14 - JACKSONVILLE

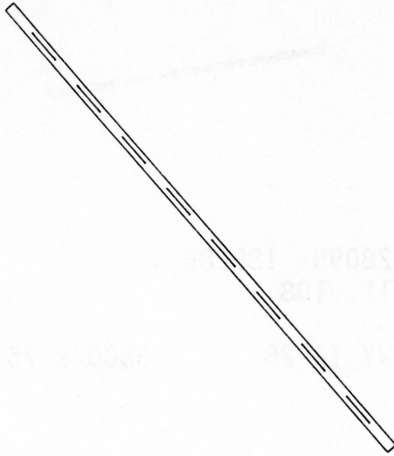

Moultrie

Spence

12591N 18166E
alt. 292

RWY 14-32 8000 x 150



Ocala Muni (Taylor Fld)

11773N 18769E
alt. 90

RWY 18-36 5007 x 150
RWY 8-26 3009 x 50

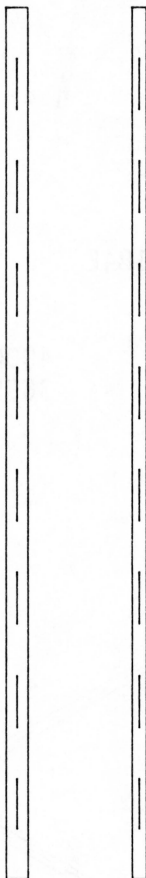

Orlando

Orlando Intl

11466N 19139E
alt. 96

RWY 18R-36L	12004 x 300
RWY 18L-36R	12004 x 200

16 - JACKSONVILLE

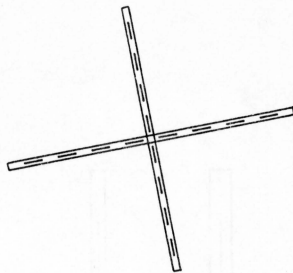

Ormond Beach Muni

11857N 19184E
alt. 29

RWY 8-26	4000 x 100
RWY 17-35	3695 x 100

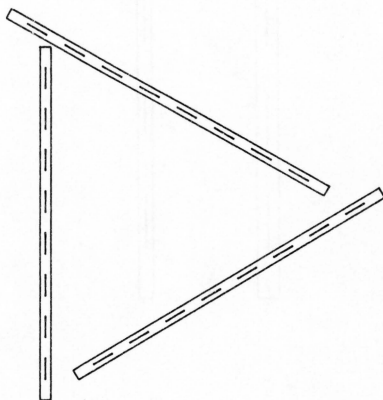

Perry - Foley

12132N 18237E
alt. 45

RWY 12-30	5013 x 150
RWY 6-24	4900 x 150
RWY 18-36	4900 x 150

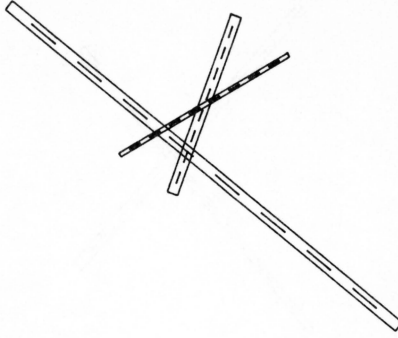

St Augustine

12137N 19080E
alt. 10

RWY 6947 x 150
RWY 2600 x 75
RWY 2700 x 60

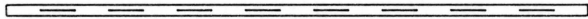

Tallahassee

Tallahassee Muni (F)

12257N 17942E
alt. 81

RWY 9R-27L 8000 x 150
RWY 18-36 6066 x 150
RWY 9L-27R 3328 x 100

18 - JACKSONVILLE

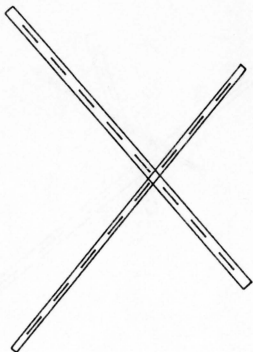

Thomasville

Thomasville Muni

12483N 18102E
alt. 264

RWY 4-22	5000 x 100
RWY 14-32	5000 x 150

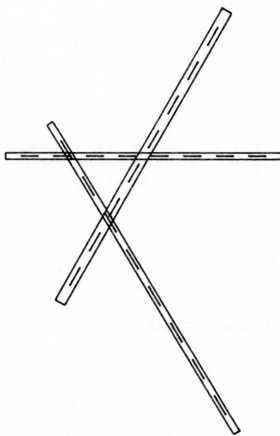

Tifton

Henry Tift Myers

12712N 18239E
alt. 355

RWY 15-33	4994 x 120
RWY 9-27	3805 x 95
RWY 3-21	3389 x 75

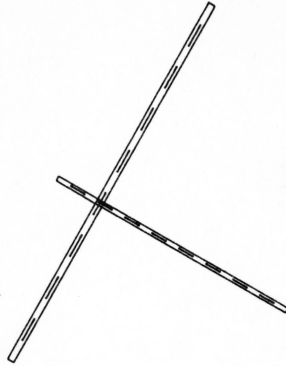

Valdosta Regional

12446N 18332E
alt. 204

RWY 17-35	6302 x 150
RWY 3-21	5596 x 100
RWY 12-30	3628 x 75

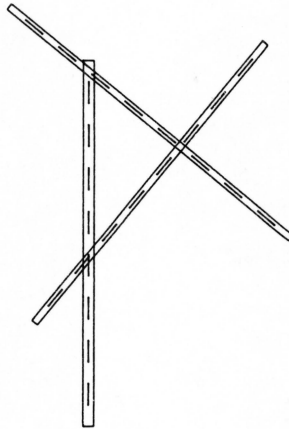

Waycross-Ware Co

12667N 18645E
alt. 142

RWY 18-36	5042 x 150
RWY 13-31	5012 x 100
RWY 4-22	5035 x 100

20 - JACKSONVILLE

Alma (VOR)

12788N 18591E
freq. 115.1

Brooksville (NDB)

11463N 18701E
freq. 278

Brunswick (VOR)

12606N 19005E
freq. 109.8

Caidy (NDB)

12472N 18003E
freq. 338

Camilla (NDB)

12610N 17965E
freq. 369

Cape Canaveral (NDB)

11515N 19429E
freq. 313

Cross City (VOR)

11933N 18447E
freq. 112

DeLand (NDB)

11753N 19131E
freq. 201

Dinns (NDB)

12343N 18890E
freq. 344

Donalsonville (NDB)

12512N 17735E
freq. 352

Gainesville (VOR)

11939N 18706E
freq. 116.2

Geiger Lake (NDB)

11562N 19315E
freq. 375

Herlong (NDB)

12261N 18893E
freq. 332

Homerville (NDB)

12576N 18511E
freq. 209

Jacksonville (VOR)

12299N 19003E
freq. 114.5

Kissimmee (NDB)

11415N 19099E
freq. 329

22 - JACKSONVILLE

Lakeland (VOR)

11251N 18885E
freq. 116

Leesburg (NDB)

11631N 18934E
freq. 335

Melbourne (VOR)

11358N 19399E
freq. 110

Ocala (VOR)

11773N 18768E
freq. 113.7

Orlando (VOR)

11527N 19127E
freq. 112.2

Ormond Beach (VOR)

11859N 19185E
freq. 112.6

Patten (NDB)

12510N 18123E
freq. 245

Sanford (NDB)

11629N 19156E
freq. 408

Satellite (NDB)

11355N 19383E
freq. 257

Savannah (VOR)

13103N 19057E
freq. 112.7

St Augustine (VOR)

12140N 19073E
freq. 109.4

St Johns (NDB)

12322N 19045E
freq. 306

St. Petersburg (VOR)

11203N 18631E
freq. 116.4

Tallahassee (VOR)

12326N 17928E
freq. 117.5

Taylor (VOR)

12340N 18607E
freq. 112.9

Taylor (VOR)

12342N 18605E
freq. 112.9

24 - JACKSONVILLE

Tift Myers (VOR)

12712N 18235E
freq. 112.5

Valdosta (VOR)

12402N 18332E
freq. 110.4

Vidalia (NDB)

13076N 18622E
freq. 372

Wakul (NDB)

12227N 17938E
freq. 379

Waycross (VOR)

12672N 18581E
freq. 110.2

Wynds (NDB)

11986N 18777E
freq. 269

Amdt 3
ILS RWY 13

AL-5570 (FAA)

JACKSONVILLE INTERNATIONAL (JAX)
JACKSONVILLE, FLORIDA

JACKSONVILLE APP CON
119.0 335.6
JACKSONVILLE TOWER
118.3 317.7
GND CON
121.9 348.6
CLNC DEL
119.5 348.6
ASR
ATIS 125.85

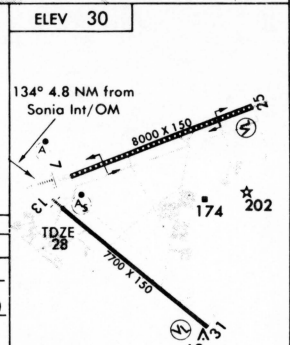
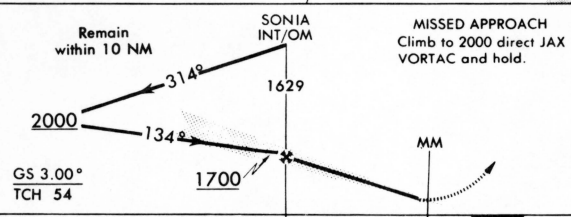
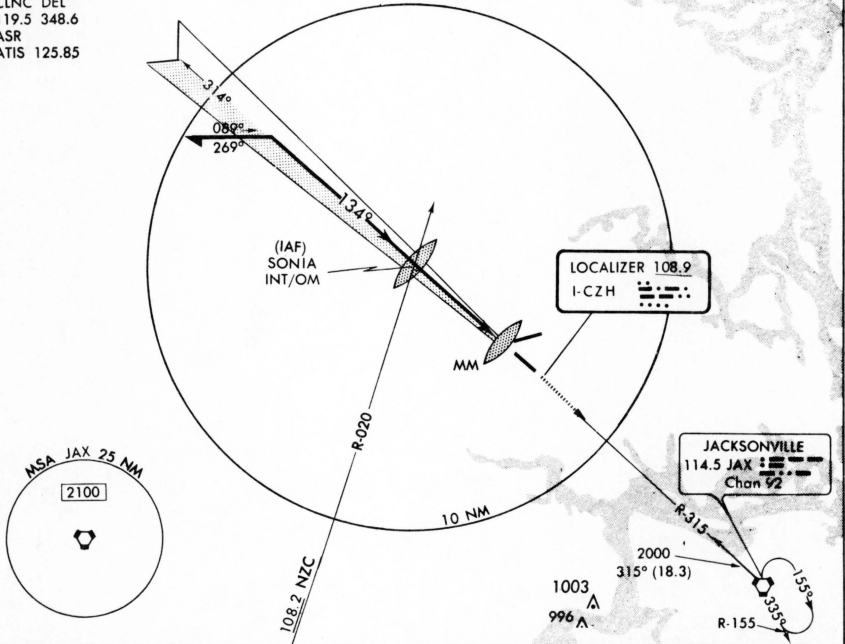

CATEGORY	A	B	C	D
S-ILS 13		228-1/2	200 (200-1/2)	
S-LOC 13		380-1/2	352 (400-1/2)	380-3/4 352 (400-3/4)
CIRCLING	500-1	470 (500-1)	500-1 1/2 470 (500-1 1/2)	580-2 550 (600-2)

Cat. D S-LOC visibility increased 1/4 mile for inoperative MM.

FAF to MAP 4.8 NM					
Knots	60	90	120	150	180
Min:Sec	4:48	3:12	2:24	1:55	1:36

ILS RWY 13

30° 30' N-81° 41' W

JACKSONVILLE, FLORIDA
JACKSONVILLE INTERNATIONAL (JAX)

JACKSONVILLE INTERNATIONAL
AIRPORT

APPROACH

ILS RWY 13

JACKSONVILLE
 APPROACH
 ILS RWY 13
 13L
 13R
 13C
 13D
 13E
 13F
 13G
 13H
 13I
 13J
 13K
 13L
 13M
 13N
 13O
 13P
 13Q
 13R
 13S
 13T
 13U
 13V
 13W
 13X
 13Y
 13Z

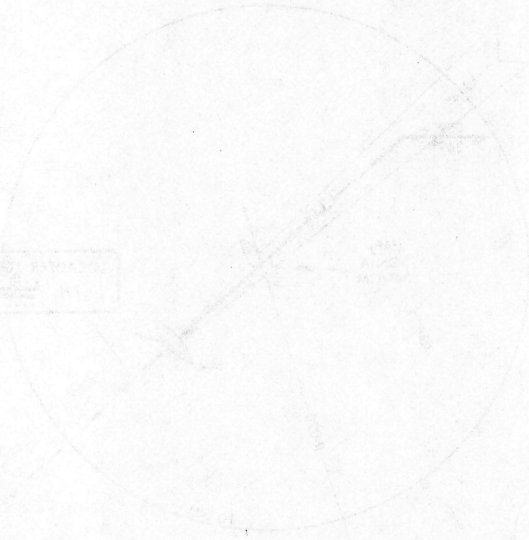

Category	Frequency	Power	Height	Remarks
ILS	111.750	500W	300'	ILS RWY 13
Localizer	111.750	500W	300'	Localizer RWY 13
Marker	135.000	100W	100'	Marker RWY 13
ILS	111.750	500W	300'	ILS RWY 13
Localizer	111.750	500W	300'	Localizer RWY 13
Marker	135.000	100W	100'	Marker RWY 13

JACKSONVILLE INTERNATIONAL
AIRPORT

APPROACH

ILS RWY 13



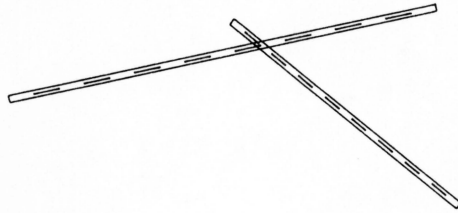

Ft Lauderdale, Ft Lauderdale Exec

10532N 19650E
alt. 14

RWY 8-26	6001 x 100
RWY 13-31	3999 x 100

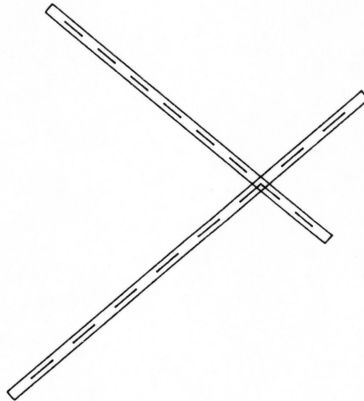

Ft Myers, Page Fld

10651N 18984E
alt. 18

RWY 5-23	6401 x 150
RWY 13-31	4997 x 150

2 - MIAMI

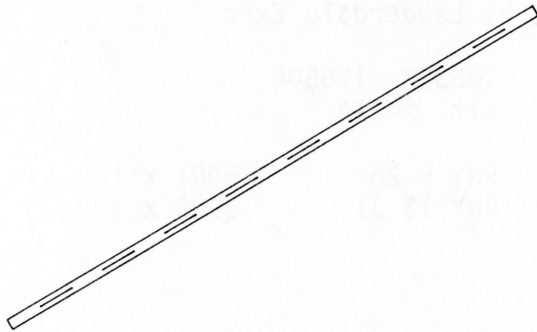

Ft Myers, SW Florida Regional

10634N 19027E
alt. 31

RWY 6-24 8400 x 150

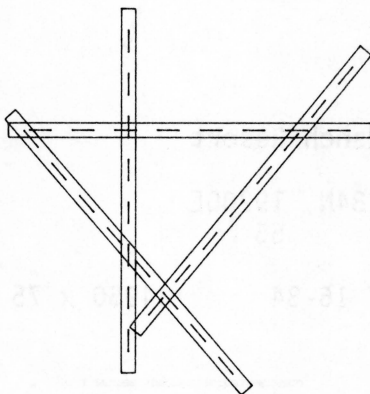

Ft Pierce, St Lucie Co Intl

11083N 19528E
alt. 24

RWY 9-27	5000 x 200
RWY 4-22	5000 x 200
RWY 14-32	5000 x 100
RWY 18-36	5000 x 200

4 - MIAMI



Frostproof, River Ranch Resort

11184N 19200E
alt. 55

RWY 16-34 4950 x 75



Homestead General

10223N 19528E
alt. 9

RWY 18-36 4000 x 100
RWY 9-27 3000 x 75

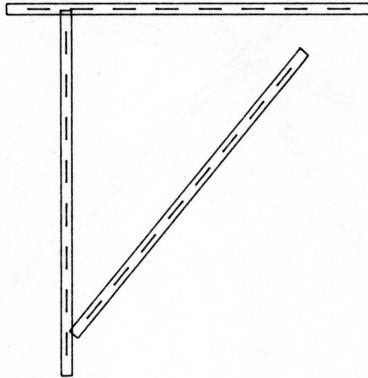

Immokalee, Immokalee

10599N 19167E
alt. 37

RWY 4-22	5000 x 150
RWY 9-27	5000 x 150
RWY 18-36	5000 x 150

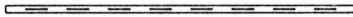

Key West, Key West Intl

9779N 19085E
alt. 4

RWY 9-27	4800 x 100
----------	------------

6 - MIAMI

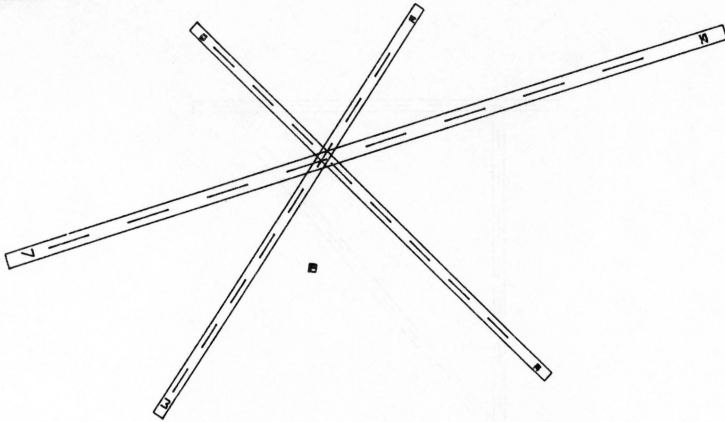

Key West, NAS Key West (F)

9790N 19114E
alt. 6

RWY 7-25	10000 x 200
RWY 3-21	7000 x 150
RWY 13-31	7000 x 150



La Belle, La Belle

10732N 19147E
alt. 18

RWY 14-32	3810 x 50
-----------	-----------

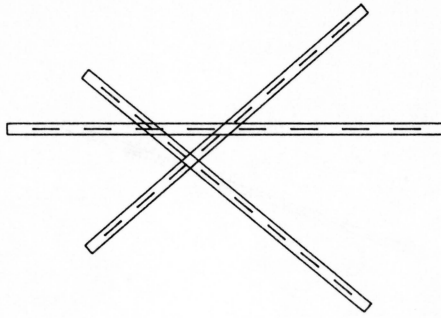

Lakeland, Lakeland Muni

11254N 18885E
alt. 142

RWY 9-27	6000 x 150
RWY 13-31	5002 x 150
RWY 5-23	5000 x 150

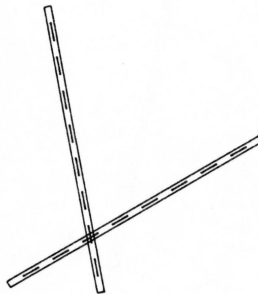

Lake Wales, Lake Wales Muni

11220N 19039E
alt. 125

RWY 6-24	4000 x 100
RWY 17-35	4000 x 100

8 - MIAMI

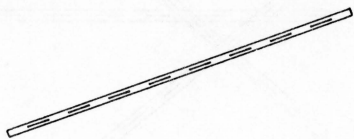

Marathon

9873N 19356E
alt. 6

RWY 7-25 5000 x 100



Marco Island, Marco

10402N 19075E
alt. 6

RWY 17-35 5008 x 100

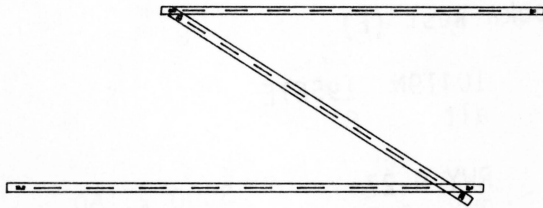

Miami, Miami Intl (F)

10357N 19615E
alt. 10

RWY 9R-27L	13002 x 150
RWY 9L-27R	10502 x 200
RWY 12-30	9601 x 150

ILS 27R

FREQUENCY:	109.1
HEADING:	270
ALTITUDE:	1369 ft. @ LOM

10 - MIAMI



Miami, Opa Locka West (F)

10419N 19561E
alt. 8

RWY 9-27 3000 x 150
RWY 18-36 3000 x 150

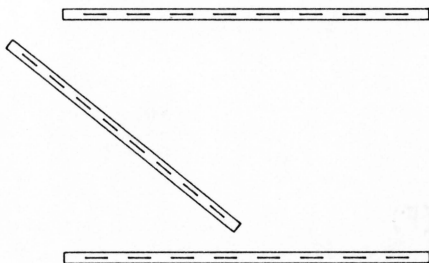

Miami, Tamiami

10288N 19569E
alt. 10

RWY 9L-27R 5002 x 150
RWY 9R-27L 4999 x 150
RWY 13-31 4001 x 150

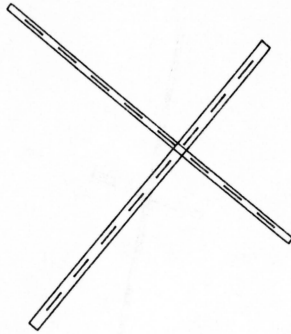

Naples, Naples Muni

10468N 19028E
alt. 9

RWY 4-22	5000 x 150
RWY 13-31	5000 x 100

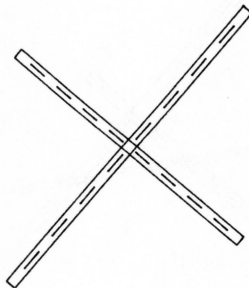

Okeechobee, Okeechobee Co

10970N 19354E
alt. 34

RWY 4-22	5000 x 150
RWY 13-31	4000 x 100

12 - MIAMI

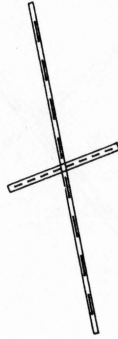

Pahokee, Palm Beach Co Glades

10770N 19429E
alt. 17

RWY 17-35	4620 x 75
RWY 7-25	1617 x 100

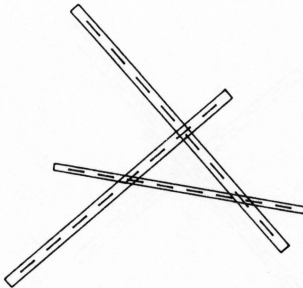

Pompano Beach, Pompano Beach Airpark

10558N 19674E
alt. 20

RWY 14-32	4420 x 150
RWY 5-23	4000 x 150
RWY 10-28	3500 x 100

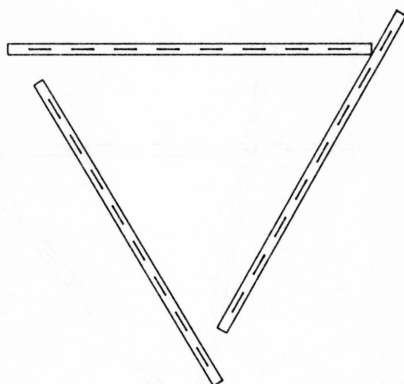

Punta Gorda, Charlotte Co

10791N 18922E
alt. 25

RWY 3-21	5000 x 150
RWY 9-27	5000 x 150
RWY 15-33	4800 x 150

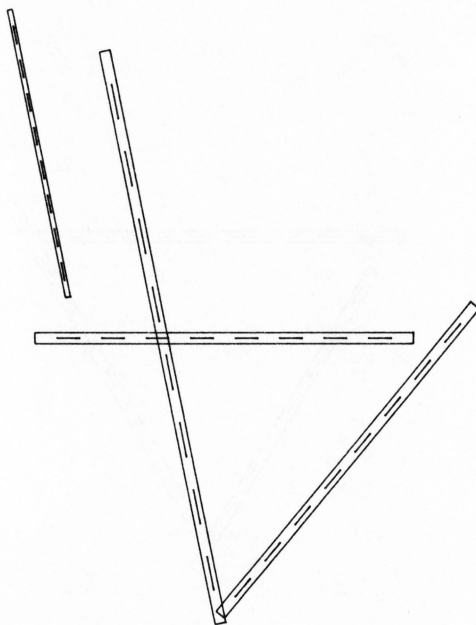

St Petersburg-Clearwater Intl

11205N 18630E
alt. 11

RWY 17L-35R	7989 x 150
RWY 4-22	5500 x 150
RWY 9-27	5165 x 150
RWY 17R-35L	4000 x 75

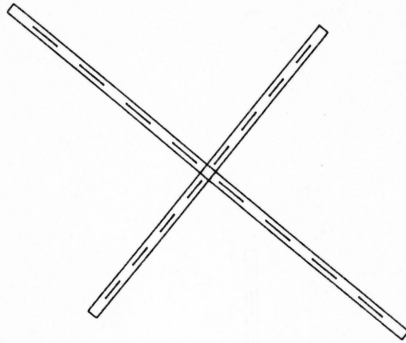

Sarasota, Sarasota-Bradenton

10983N 18696E
alt. 28

RWY 14-32	7003 x 150
RWY 4-22	5004 x 150

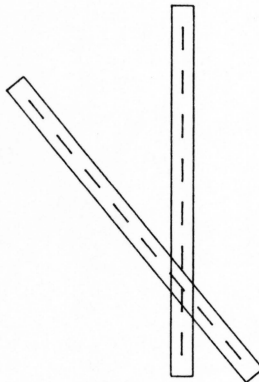

Sebring, Sebring Airport and Industrial Park

11041N 19160E
alt. 63

RWY 18-36	5190 x 300
RWY 14-32	5190 x 300

16 - MIAMI

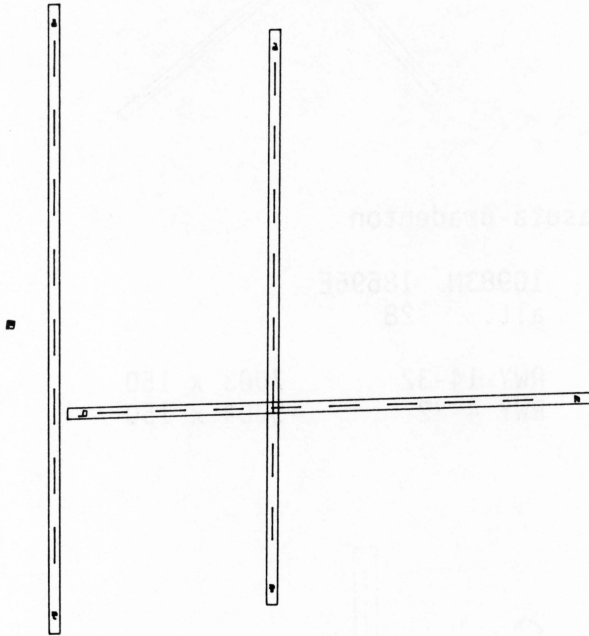

Tampa, Tampa Int'l (F)

11240N 18690E
alt. 27

RWY 18R-36L	11000 x 150
RWY 18L-36R	8300 x 150
RWY 9-27	6998 x 150

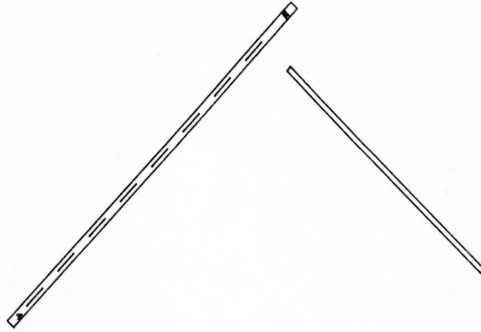

Tampa, MacDill AFB

11186 18704
alt. 14

RWY 4-22 11420 x 250

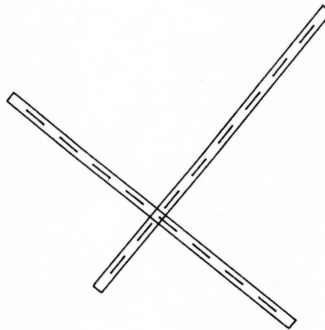

Venice, Venice Muni

10845N 18748E
alt. 19

RWY 4-22 5000 x 150
RWY 13-31 5000 x 150

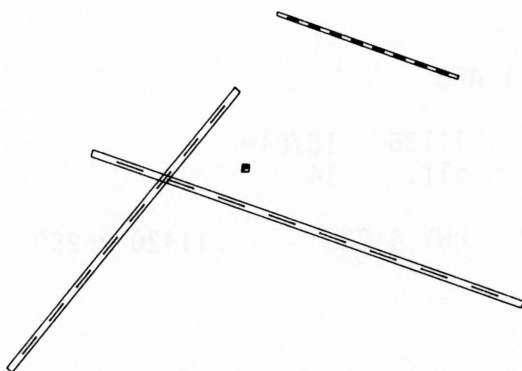

Vero Beach, Vero Beach Muni (F)

11154N 19505E
alt. 25

RWY 11R-29L	7180 x 100
RWY 4-22	4975 x 100
RWY 11L-29R	2637 x 50

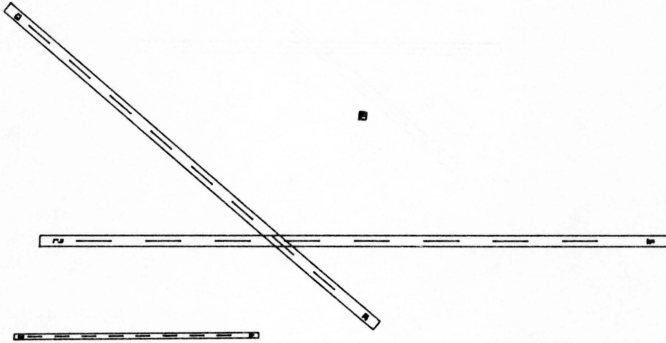

West Palm Beach, Palm Beach Intl (F)

10746N 19662E
alt. 19

RWY 9L-27R	7989 x 150
RWY 13-31	6930 x 150
RWY 9R-27L	3152 x 75

ATIS: 123.75

ILS 9L

FREQUENCY:	109.3
HEADING:	96
ALTITUDE:	1906 ft @LOM

20 - MIAMI

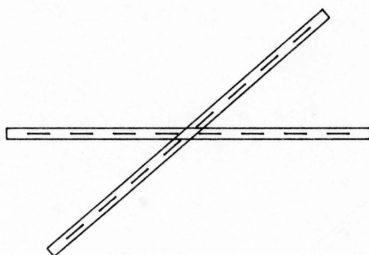

Winter Haven, Bartow Muni

11241N	18979E
alt.	128
RWY 5-23	5000 x 100
RWY 9-27	5000 x 150



Congo Town

9749N	20746E
alt.	15
RWY 10-28	5000 x 100

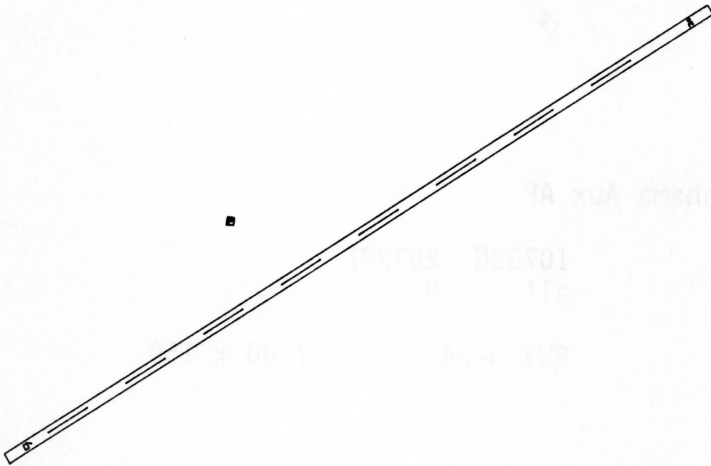

Freeport Int'l (F)

10737N 20209E
alt. 7

RWY 6-24 11000 x 150

22 - MIAMI

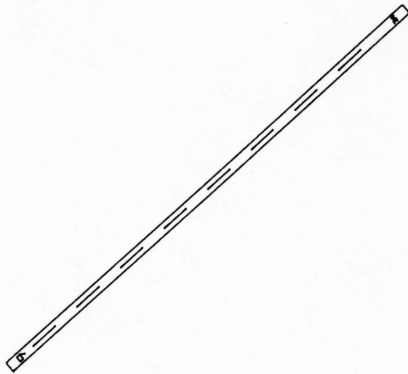

Grand Bahama Aux AF

10782N 20338E
alt. 9

RWY 6-24 7200 x 150

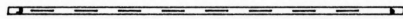

Marsh Harbour

10783N 20830E
alt. 10

RWY 9-27 5000 x 150

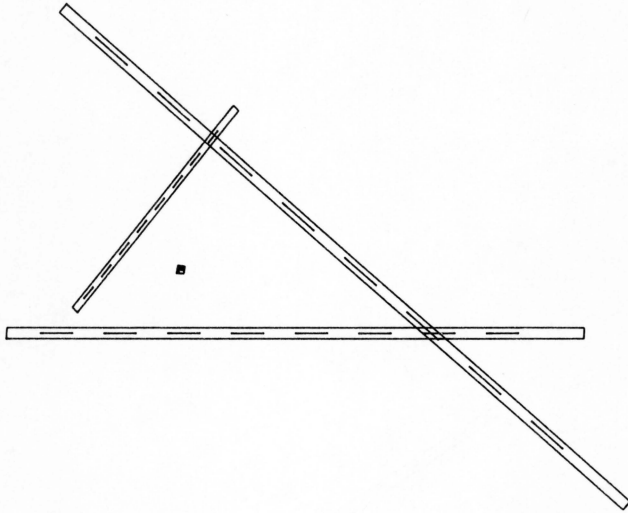

Nassau Int'l (F)

10136N 20749E
alt. 10

RWY 13-31	11000 x 150
RWY 9-27	8000 x 150
RWY 4-22	2700 x 100

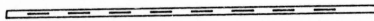

South Bimini

10350N 20020E
alt. 10

RWY 9-27	5000 x 150
----------	------------

24 - MIAMI

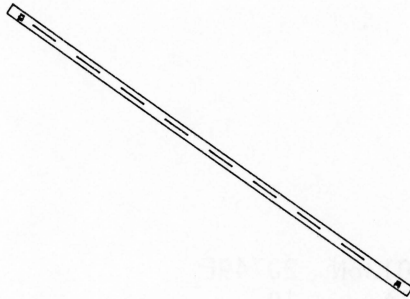

Treasure Cay

10871N 20702E
alt. 11

RWY 13-31 7000 x 150

Bimini (VOR)

10350N 20011E
freq. 116.7

Biscayne Bay (VOR)

10306N 19668E
freq. 117.1

Cape Canaveral (NDB)

11515N 19429E
freq. 313

Cook (NDB)

10356N 19596E
freq. 365

Deland (NDB)

11753N 19131E
freq. 201

Fish Hook (NDB)

9774N 19073E
freq. 332

Fort Pierce (NDB)

11083N 19528E
freq. 275

Freeport (NDB)

10719N 20184E
freq. 209

26 - MIAMI

Freeport (VOR)

10735N 20210E
freq. 113.2

Ft Lauderdale (VOR)

10477N 19662E
freq. 111.4

Ft Myers (VOR)

10653N 18982E
freq. 117.6

Ft Pierce (NDB)

11084N 19529E
freq. 275

Ft. Lauderdale (VOR)

10478N 19663E
freq. 111.4

Ft. Myers (VOR)

10652N 18983E
freq. 117.6

Geiger Lake (NDB)

11562N 19315E
freq. 375

Key West (VOR)

9791N 19067E
freq. 113.5

Kissimmee (NDB)

11415N 19099E
freq. 329

La Belle (VOR)

10769N 19159E
freq. 110.4

Lakeland (VOR)

11251N 18885E
freq. 116

Leesburg (NDB)

11631N 18934E
freq. 335

Marathon (NDB)

9863N 19340E
freq. 260

Marsh Harbour (NDB)

10783N 20831E
freq. 361

Melbourne (VOR)

11346N 19407E
freq. 110

Miami (NDB)

10345N 19682E
freq. 322

28 - MIAMI

Miami (VOR)

10422N 19547E
freq. 115.9

Nassau (VOR)

10133N 20759E
freq. 112.7

Ocala ,FL (VOR)

11770N 18767E
freq. 113.7

Orlando (VOR)

11527N 19127E
freq. 112.2

Pahokee (VOR)

10772N 19430E
freq. 112.4

Palm Beach (VOR)

10742N 19667E
freq. 115.7

Perrine (NDB)

10287N 19543E
freq. 266

Plantation (NDB)

10503N 19636E
freq. 242

Punta Gorda (VOR)

10791N 18924E
freq. 110.2

Rubin (NDB)

10743N 19619E
freq. 356

Sanford (NDB)

11629N 19156E
freq. 408

Sarasota (VOR)

10985N 18695E
freq. 115.2

Satellite (NDB)

11334N 19381E
freq. 257

Sebring (NDB)

11041N 19156E
freq. 382

St. Petersburg (VOR)

11203N 18631E
freq. 116.4

Treasure Cay (NDB)

10847N 20741E
freq. 233

30 - MIAMI

Treasure Cay (VOR)

10867N 20710E
freq. 112.9

Vero Beach (VOR)

11162N 19478E
freq. 117.3

Amdt 10
ILS RWY 27R

AL-257 (FAA)

MIAMI INTERNATIONAL (MIA)
MIAMI, FLORIDA

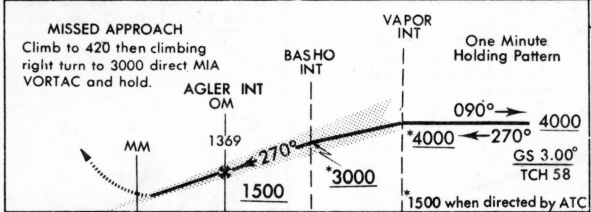
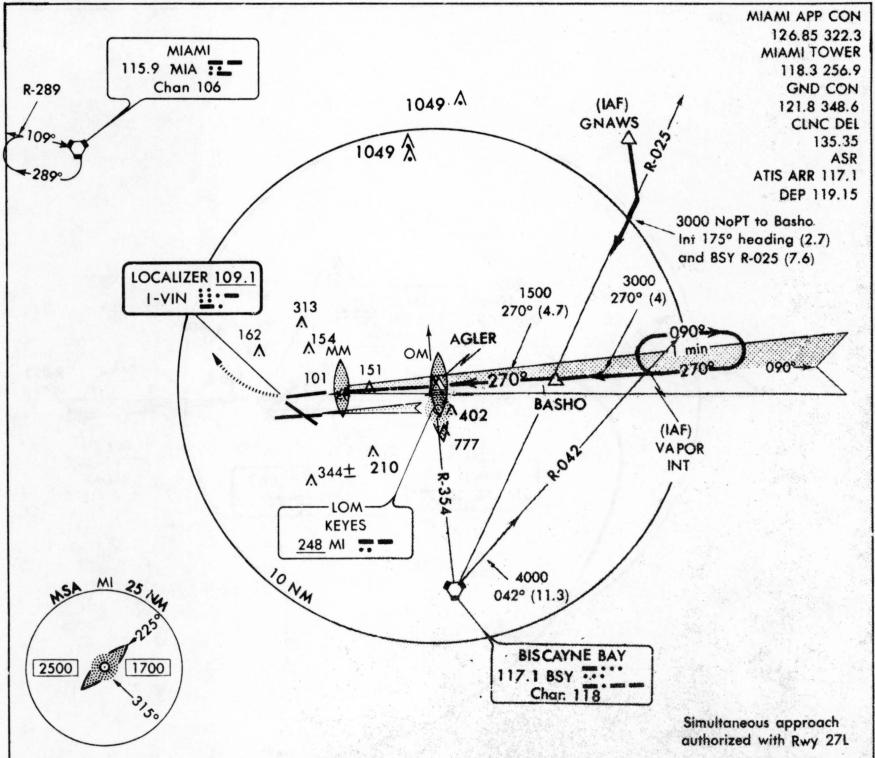

CATEGORY	A	B	C	D
S-ILS 27R		210-½	200 (200-½)	
S-LOC 27R	460-½	450 (500-½)	460-¾ 450 (500-¾)	460-1 450 (500-1)
CIRCLING	NA			

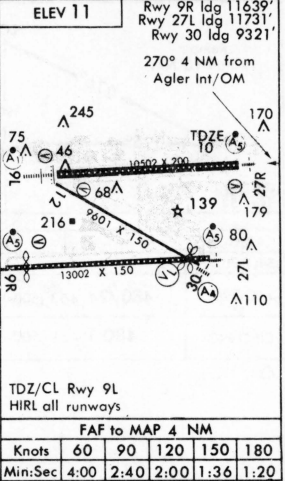

ILS RWY 27R

25°48'N - 80°17'W

MIAMI, FLORIDA
MIAMI INTERNATIONAL (MIA)

Amdt 21
ILS RWY 9L

WEST PALM BEACH/PALM BEACH INTL (PBI)
 WEST PALM BEACH, FLORIDA

PALM BEACH APP CON
 124.6 317.4
 PALM BEACH TOWER
 119.1 257.8
 GND CON
 121.9
 CLNC DEL
 121.6
 ASR
 ATIS 123.75

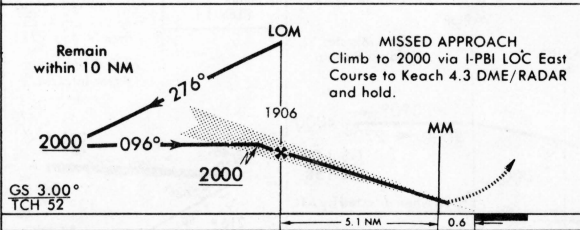
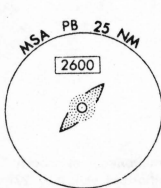
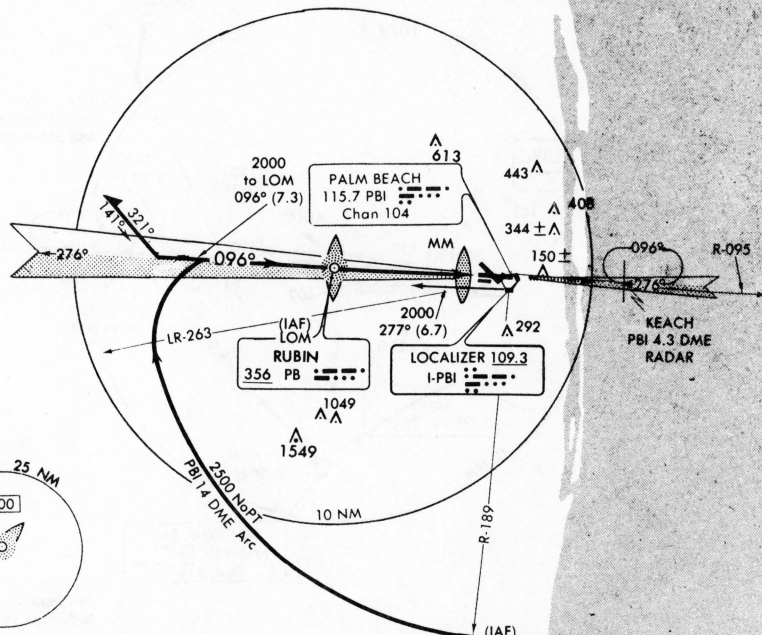

CATEGORY	A	B	C	D
S-ILS 9L	217/24 200 (200-½)			
S-LOC 9L	480/24 463 (500-¼)	480/40 463 (500-¾)	480/50 463 (500-1)	
CIRCLING	480-1 461 (500-1)	500-1½ 481 (500-1½)	660-2 641 (700-2)	

ELEV 19 Rwy 31 ldg 6502'

REIL Rws 13, 27R and 31
 MIRL Rwy 13-31
 HIRL Rwy 9L-27R

FAF to MAP 5.7 NM

Knots	60	90	120	150	180
Min:Sec	5:42	3:48	2:51	2:17	1:54

ILS RWY 9L

26°41'N-80°06'W
 WEST PALM BEACH, FLORIDA
 WEST PALM BEACH/PALM BEACH INTL (PBI)